

# Medtronic

## Micra™ AV MC1AVR1



MR Conditional dual chamber transcatheter pacing system with SureScan™ technology (VDD)

Device Manual

**Caution:** Federal law (USA) restricts this device to sale by or on the order of a physician.

The following list includes trademarks or registered trademarks of Medtronic in the United States and possibly in other countries. All other trademarks are the property of their respective owners.

Capture Management, Marker Channel, Medtronic, Micra, Quick Look, SureScan

# Contents

<b>1</b>	<b>System overview</b>	<b>5</b>
1.1	Introduction	5
1.2	System description	5
1.3	Indications for use	9
1.4	Contraindications	9
1.5	Pre-implant considerations	10
1.6	Feature summary	11
1.7	Pacing mode information	12
1.8	Data security	14
<b>2</b>	<b>Warnings, precautions, and potential adverse events</b>	<b>15</b>
2.1	General warnings and precautions	15
2.2	Explant and disposal under care	17
2.3	Explant and disposal postmortem	18
2.4	Handling and storage instructions	18
2.5	Device operation	19
2.6	Warnings, precautions, and guidance for clinicians performing medical procedures on cardiac device patients	21
2.7	Warnings, precautions, and guidance related to electromagnetic interference (EMI) for cardiac device patients	29
2.8	Physician training	38
2.9	Potential adverse events	38
2.10	Adverse events and clinical trial data	40
<b>3</b>	<b>Drug information</b>	<b>41</b>
3.1	Mechanism of action	41
3.2	Pharmacokinetics and metabolism	41
3.3	Mutagenesis, carcinogenicity, and reproductive toxicity	41
<b>4</b>	<b>Implant procedure</b>	<b>43</b>
4.1	Preparing for an implant	43
4.2	Implanting the device	47
4.3	Implanting a new Micra AV device in a patient with an existing Micra device	59
4.4	Retrieving and repositioning the device after the tether removal	63

<b>5</b>	<b>Product specifications</b>	<b>68</b>
5.1	Physical characteristics	68
5.2	Electrical specifications	69
5.3	Replacement indicators	70
5.4	Projected service life	71
<b>6</b>	<b>Device parameters</b>	<b>74</b>
6.1	Emergency settings	74
6.2	Pacing parameters	74
6.3	Data collection setup parameters	77
6.4	Test parameters	78
6.5	Nonprogrammable parameters	79
<b>7</b>	<b>Packaging symbols and declaration of conformity</b>	<b>80</b>
7.1	Declaration of compliance to standards	80
7.2	Explanation of symbols	80

# 1 System overview

## 1.1 Introduction

This manual describes the Medtronic Micra™ AV Model MC1AVR1 MR Conditional dual chamber transcatheter pacing system (VDD). It contains feature descriptions, indications and contraindications, warnings and precautions, instructions for implanting the device, quick reference specifications, and parameter tables.

The following manuals and documents also contain information about the device:

**MRI technical manual** – This manual provides MRI-specific procedures and warnings and precautions.

**Reference manual** – This manual contains detailed information about the functionality of Micra AV device features.

**Programming guide** – This manual explains how to use the programmer software to conduct a patient session.

**Radio regulatory compliance information** – This document provides compliance information related to the radio components of the device.

## 1.2 System description

The Medtronic Micra AV Model MC1AVR1 MR Conditional dual chamber, transcatheter pacing system with SureScan technology is a programmable cardiac device that monitors and regulates the patient's heart rate by providing rate-responsive bradycardia pacing to the right ventricle and AV synchrony based on the mechanical sensing of atrial activity.

The device senses both the electrical activity and the mechanical activity of the patient's heart using sensing and pacing electrodes and an accelerometer enclosed in a miniature titanium capsule. It monitors the heart for bradycardia and AV synchrony. It also provides the following features for patients:

- The device responds to bradycardia by providing pacing therapy based on programmed pacing parameters.
- The device provides AV synchrony based on sensed mechanical activity in the atrium.
- The device provides diagnostic and monitoring information to evaluate device performance and to provide the best possible patient care.

**Figure 1.** Implanted Micra AV Model MC1AVR1 transcatheter pacing system

---

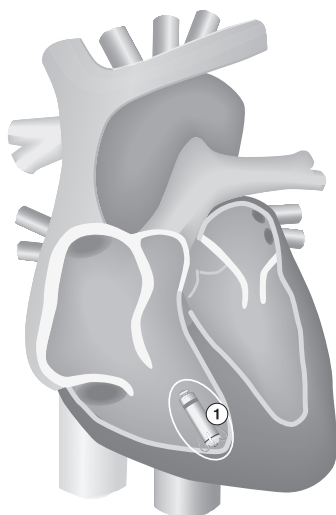

---

1 The device implant location in the right ventricle

---

The MRI SureScan feature permits a mode of operation that allows a patient with a SureScan system to be safely scanned by an MRI machine while the device continues to provide appropriate pacing. When programmed to On, MRI SureScan operation disables all user-defined diagnostics. Before performing an MRI scan, refer to the MRI technical manual.

The users of this device include medical professionals (physicians, nurses, technicians, and their supporting staff) trained in surgery, cardiology, radiology, and magnetic resonance (MR) technology and able to implement the procedures documented in the instructions for use for this device.

The components of the Micra AV Model MC1AVR1 transcatheter pacing system are shown in the following figure:

**Figure 2.** System components

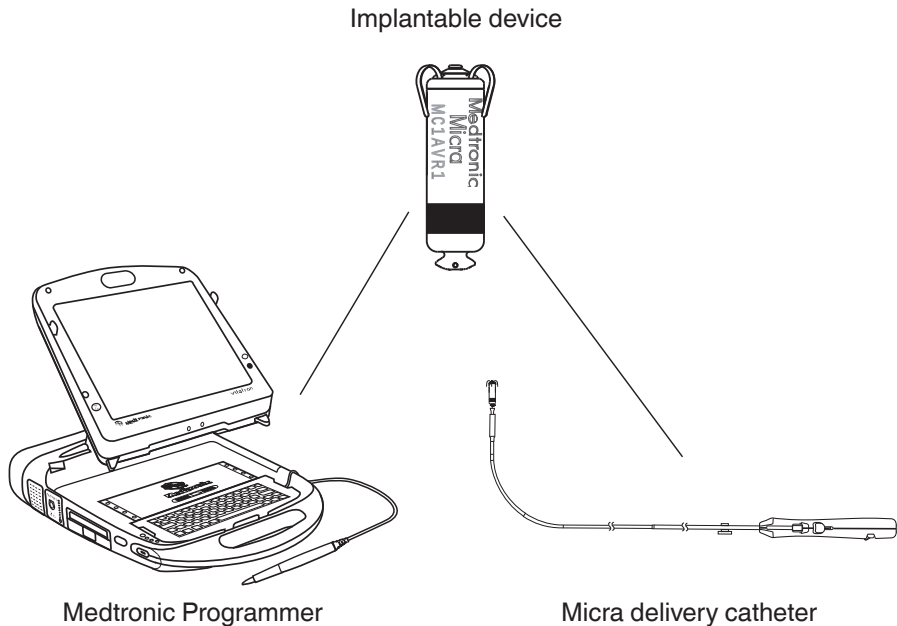

### 1.2.1 Intended use

Transcatheter pacing systems are sterile, single-use only, active implantable medical devices that are implanted in patients by health care professionals trained in cardiology. Transcatheter pacing systems are intended to improve cardiac output, prevent symptoms of and protect against arrhythmias related to cardiac impulse formation or conduction disorders by providing pacing therapy to the heart.

### 1.2.2 Usage environments

The device is intended to be used in the following environments and conditions:

- The device will be implanted in a properly equipped, staffed, and sterile surgical environment. Implant will take place under standard surgical protocols and in the patient population for which the device is indicated.
- Post-surgical patient and device follow-up care will take place in a properly equipped and staffed cardiology clinic or office.
- MRI procedures for patients with this device will take place in a properly equipped and staffed MR facility, and in consideration of the conditions and requirements described in the MRI technical manual.

- After having an implant, patients may resume their lives at home, at work, and in other environments in consideration of physician orders, and in consideration of the advice and restrictions documented in this manual and in the patient literature.

### 1.2.3 System components and accessories

**Contents of sterile package** – The sterile package contains 1 implantable transcatheter pacing system, which includes the implantable device and delivery catheter system.

The Micra AV transcatheter pacing system is sterilized with ethylene oxide gas and packaged in a pouch that contains a sterile aseptic tray. The tray is designed to ease the placement of the pacing system in the sterile field. For the pacing system to be sterile, the pouch must not be damaged or opened. The outer surfaces of the pouch are **nonsterile** and must not be placed in the sterile field.

For instructions to open the sterile package, see Section 4.1.5, “How to open the sterile package”, page 45.

**Implantable device** – The Micra AV Model MC1AVR1 is a dual chamber transcatheter pacing system that provides AV synchronous pacing and bipolar sensing and pacing in the right ventricle. The device has an active fixation mechanism consisting of 4 electrically inactive tines designed to anchor the device in the cardiac tissue at the implant location in the right ventricle.

**MRI SureScan feature** – Patients with an implanted Micra AV Model MC1AVR1 pacing system can undergo an MRI scan if the system meets the requirements described in the Micra AV Model MC1AVR1 MRI technical manual. The MRI SureScan pacing feature allows the patient to be safely scanned while the device continues to provide appropriate pacing. Before performing an MRI procedure, refer to the Micra AV Model MC1AVR1 MRI technical manual for important information about procedures and MRI-specific contraindications, warnings, and precautions.

**Device delivery catheter system** – The Micra AV delivery catheter system consists of the following parts:

- A delivery catheter designed to carry, deliver, and position the device for implant in the right ventricle by accessing this chamber through the femoral vein. The delivery catheter has a steerable, flexible shaft with a rigid distal end that contains a device cup to hold the device and a recapture cone to retrieve it. The delivery catheter is compatible with a 7.8 mm (23 Fr) introducer sheath that is 56 cm (22 in) long or longer, such as the Medtronic Micra Introducer.
- A handle with controls to navigate the delivery catheter and deploy the device. The handle also provides a tether designed as an aid to test the device fixation and to recapture and reposition the device for proper fixation during the implant procedure.

**Programmer and software** – The Medtronic programmer and software are used to program the device for implant testing and patient follow-up sessions. The use of a Medtronic programming head is required for communication between the device and the



programmer. Programmers from other manufacturers are not compatible with Medtronic devices but will not damage Medtronic devices.

### **1.3 Indications for use**

Micra AV Model MC1AVR1 is indicated for use in patients who have experienced one or more of the following conditions:

- Paroxysmal or permanent high-grade AV block in the presence of AF
- Paroxysmal or permanent high-grade AV block in the absence of AF, as an alternative to dual chamber pacing, when a dual-chamber transvenous pacing system is considered difficult, high risk, or not deemed necessary for effective therapy
- Symptomatic bradycardia-tachycardia syndrome or sinus node dysfunction (sinus bradycardia or sinus pauses), as an alternative to atrial or dual chamber pacing, when a dual-chamber transvenous pacing system is considered difficult, high risk, or not deemed necessary for effective therapy

The device is also indicated for VDD pacing in patients with adequate sinus rates who may benefit from maintenance of AV synchrony. The Micra AV device provides AV synchronous ventricular pacing similar to a transvenous VDD system. The implanted device depends on the appropriate sensing of atrial mechanical signals to achieve AV synchrony. The level of AV synchrony may vary in individual patients and may not be predictable prior to implant.

Rate-responsive pacing is indicated to provide increased heart rate appropriate to increasing levels of activity.

The device is designed to be used only in the right ventricle.

### **1.4 Contraindications**

Micra AV Model MC1AVR1 devices are contraindicated for use in the following situations:

- If an implanted inferior vena cava filter is present
- If a mechanical tricuspid valve is present
- If another implanted cardiac device providing active cardiac therapy may interfere with the sensing performance of the Micra device
- If another implanted device would interfere with the implant of the Micra device in the judgment of the implanting physician
- If femoral venous anatomy is unable to accommodate a 7.8 mm (23 Fr) introducer sheath or implant on the right side of the heart (for example, due to obstructions or severe tortuosity)
- If morbid obesity prevents the implanted device from obtaining adequate telemetry communication within 12.5 cm (4.9 in)
- If known intolerance to heparin or the tissue contacting materials in the device exists
- If sensitivity to contrast media cannot be adequately premedicated
- If the steroid dose from this device cannot be tolerated

For the MRI contraindications for patients with a Micra AV MRI device, refer to the Micra AV MRI technical manual.

## 1.5 Pre-implant considerations

The Micra AV device is intended to provide AV synchrony at rest and VVIR pacing during periods of high patient activity. Synchronous ventricular pacing using sensing of atrial mechanical contraction may not provide continuous AV synchrony. Device-mediated AV synchrony can vary depending on patient condition and activity levels, and it can be limited at high sinus rates. During periods of intermittent AV synchrony, the device will provide ventricular pacing support with increased potential for pacing rate variability.

The decision to implant the Micra AV device should consider the benefits of leadless pacing versus the patient's need for continuous AV synchrony.

Some patients will not benefit from the AV synchronous (VDD) mode. Patients with the following conditions should be considered for a dual-chamber transvenous pacing system:

- Sinus node dysfunction
- High sinus rates requiring atrial tracking
- Weak atrial contraction
- Symptoms during loss of AV synchrony
- Frequent premature atrial or ventricular contractions where atrial tracking is required immediately after the premature beat

Patient evaluation for the implant of Micra AV Model MC1AVR1 should include that the Micra AV device is not intended to be removed following the End of Service (EOS) condition.

Patient evaluation for the implant of Micra AV Model MC1AVR1 should include the following consideration about a concomitant implant with a neurostimulator:

**Concomitant neurostimulator and cardiac device implants** – Some patients have medical conditions that require the implant of both a neurostimulator and a cardiac device (for example, a pacemaker, a defibrillator, or a monitor). In this case, physicians (for example, a neurologist, a neurosurgeon, a cardiologist, and a cardiac surgeon) involved with either device should contact Medtronic Technical Services or their Medtronic representative before implanting the patient with the second device. Based on the particular devices that the physicians have prescribed, Medtronic can provide the necessary precautions and warnings related to the implant procedure. For information about how to contact Medtronic, see the telephone numbers and addresses provided on the back cover of this manual.

**Note:** The Micra AV device has not been tested with active coexisting devices.

## 1.6 Feature summary

For a list of the features that are enabled at shipping, see Chapter 6, “Device parameters”, page 74.

### 1.6.1 Pacing features

**Auto PVARP** – This feature adjusts the post-ventricular atrial refractory period (PVARP) in VDD mode in response to changes in the patient’s heart rate or pacing rate. PVARP is longer at lower tracking rates to prevent pacemaker-mediated tachycardia and shorter at higher rates to maintain 1:1 tracking.

**Capture Management** – This feature monitors and manages pacing thresholds in the right ventricle to ensure that the myocardium is consistently captured in consideration of changing patient conditions.

**Atrial mechanical sensing** – The atrial mechanical sensing feature interprets mechanical activity that is generated by the cardiac cycle as signals. These signals include a signal for atrial contraction. If necessary, the device delivers a synchronous ventricular pace following an atrial contraction signal.

**MRI SureScan** – This feature allows patients with an implanted MRI SureScan device to have a safe MRI procedure if the requirements provided in the MRI technical manual are followed.

**Mode switch** – The device provides 2 types of mode switch:

- **Activity Mode Switch** engages when the device is programmed to the VDD pacing mode but patient activity raises the intrinsic heart response to a rate that is better paced by a rate-responsive pacing mode.
- **AV Conduction Mode Switch** engages when the device is programmed to the VDD pacing mode but switches to the VVI pacing mode in response to consistent intrinsic AV conduction.

**Noise reversion** – The noise reversion operation allows the device to continue pacing the heart while blocking oversensing otherwise caused by external electromagnetic interference.

**Rate Hysteresis** – This feature promotes intrinsic activity below the programmed Lower Rate. It prevents the device from overriding slow, but appropriate, intrinsic rhythms that may develop from extended periods of inactivity, such as sleep.

**Rate Profile Optimization** – Rate Profile Optimization ensures that the Rate Response feature provides appropriate pacing for the full range of patient activities. It monitors the patient’s daily sensor rate profile and adjusts the rate response curves over time to achieve a prescribed target.

**Rate Response** – This feature, also known as rate-responsive pacing, varies the device pacing rate in response to the patient’s physical activity as detected by the activity sensor of the device.

**Rate Smoothing** – This feature improves AV synchrony in cases of intermittent atrial mechanical undersensing.

**Sensed AV** – This pacing feature helps to optimize AV synchrony in the VDD pacing mode, where you can program the interval between an atrial mechanical sense and a ventricular pace.

**Tracking Check** – This feature operates when the device paces in VDD mode. Tracking Check identifies and controls undesired device pacing above the sinus rate, including device-induced tachycardias, due to atrial oversensing or external mechanical noise.

## 1.6.2 Monitoring and follow-up features

**Atrial sensing setup** – This feature is an automated post-implant process that collects atrial mechanical sensing data and then sets the atrial sensing parameters to patient-specific values, based on the collected data.

**Device diagnostics** – The device collects information on device performance over time. The following metrics are included:

- Battery voltage
- Remaining device longevity
- Electrode impedance trend
- Capture threshold trend
- R-wave amplitude trend
- A4 amplitude trend

**Holter telemetry** – This function allows the implanted device to transmit an EGM with marker telemetry continuously for up to 24 hours, regardless of the use of the programming head. Enabling Holter telemetry results in a higher consumption of the device battery. Use of a customized Holter monitor (provided by Medtronic) is required for monitoring the EGM.

**Rate Histogram** – This feature provides a programmer screen and a printable report of graphs that present ventricular and atrial ventricular event data stored by the device.

## 1.7 Pacing mode information

Pacemaker modes are described using the NBG code. The five-letter NBG code, named after The North American Society of Pacing and Electrophysiology (NASPE) and the British Pacing and Electrophysiology Group (BPEG), describes the operation of implantable pulse generators. The NBG code, which supersedes the ICHD Code, is described in Table 1.

**Table 1.** The Revised NASPE/BPEG Generic Code for antibradycardia pacing

<b>Position:</b>	<b>I</b>	<b>II</b>	<b>III</b>	<b>IV</b>	<b>V</b>
Category:	Chamber(s) Paced	Chamber(s) Sensed	Response to Sensing	Rate Modu- lation	Multisite Pacing <sup>a</sup>
	O = None A = Atrium V = Ventricle D = Dual (A + V)	O = None A = Atrium V = Ventricle D = Dual (A + V)	O = None T = Trig- gered I = Inhibited D = Dual (T + I)	O = None R = Rate modulation	O = None A = Atrium V = Ventricle D = Dual (A + V)
Manufactur- ers' designa- tion only:	S = Single <sup>b</sup> (A or V)	S = Single <sup>b</sup> (A or V)			

<sup>a</sup> Medtronic devices do not use the Multisite Pacing code.

<sup>b</sup> The programmer displays A or V (not S) for chambers paced and sensed.

### 1.7.1 Pacing modes available in Micra AV Model MC1AVR1 dual chamber pacemaker

**VDD and VDI modes** – In the VDD mode, the device uses the accelerometer to mimic dual chamber sensing by sensing atrial mechanical activity instead of atrial electrical activity. The ventricle is paced based on atrial sensed events to promote AV synchrony at lower intrinsic rates. In the VDI mode, atrial activity is sensed as it is in the VDD mode, but the ventricle is paced at the programmed lower rate, regardless of intrinsic events.

**VVIR and VVI modes** – In the VVIR mode and the VVI mode, the ventricle is paced if no intrinsic ventricular events are sensed before the current pacing interval ends. Pacing occurs at the sensor rate in the VVIR mode and at the programmed lower rate in the VVI mode.

**VOO mode** – The VOO mode provides ventricular pacing at the programmed lower rate with no inhibition by intrinsic ventricular events. In the VOO mode, no ventricular sensing occurs.

**ODO mode** – The ODO mode senses atrial mechanical activity and ventricular electrical activity. The ODO mode turns off pacing outputs, but it allows the clinician to see intrinsic AV synchrony.

**OVO mode** – The OVO mode does not deliver ventricular pacing outputs, regardless of the intrinsic rate. The OVO mode is intended only for those situations where the clinician wants to turn off bradycardia pacing outputs from the device.

**Device Off mode** – In the Device Off mode, the device does not pace or sense the heart. The Device Off mode is intended only for those situations where the clinician wants to turn off bradycardia pacing and sensing from the device.

## **1.8 Data security**

Medtronic has designed safeguards to protect patient information and device data for Micra AV transcatheter pacemakers.

Inductive telemetry communication is used through a Medtronic programming head to a Medtronic clinician programmer to interrogate and program the device. Inductive telemetry is short-range communication that protects patient information and device data.

If you experience a cybersecurity event, or if you believe that you have identified a potential security vulnerability involving a Medtronic Micra AV transcatheter pacemaker, consult the Medtronic Coordinated Disclosure Process web site at <https://www.medtronic.com/security> to report your concerns.

## 2 Warnings, precautions, and potential adverse events

### 2.1 General warnings and precautions

**Antibiotic prophylaxis with dental procedures** – Due to the lack of long-term, chronic human experience, consider the use of prophylactic antibiotics prior to dental procedures to reduce the risk of endocarditis.

**Anti-coagulation** – Appropriate anticoagulation therapy should be administered to reduce potential thrombosis.

**Anticoagulant agents, antiplatelet agents, and contrast media** – Precautions should be taken before administering anticoagulant agents, antiplatelet agents, or contrast media in patients with known hypersensitivity to these agents.

**Dexamethasone acetate use during pregnancy** – Dexamethasone acetate has been shown to be teratogenic in many species when given in doses equivalent to the human dose. There are no adequate and well-controlled studies in pregnant women. Dexamethasone acetate should be used during pregnancy only if the potential benefit justifies the potential risk to the fetus. Studies in mice, rats, and rabbits have shown that adrenocorticoids increase the incidence of cleft palate, placental insufficiency, and spontaneous abortions, and can decrease the intrauterine growth rate.

**Electrical isolation during implant** – Do not allow the patient to have contact with grounded electrical equipment that might produce electrical current leakage during implant. Electrical current leakage may induce tachyarrhythmias that may result in the patient's death.

**MRI conditions for use** – Before an MRI scan is performed on a patient implanted with the Micra AV MRI SureScan device, the cardiology and radiology professionals involved in this procedure must understand the requirements specific to their tasks. For information about MRI-specific warnings and precautions, refer to the Medtronic MRI technical manual provided for this device.

**External defibrillation equipment** – Keep external defibrillation equipment nearby for immediate use during the implant procedure, or whenever arrhythmias are possible or intentionally induced during post-implant testing.

**Mechanical vibrations in daily living** – Patient activities and environments which present mechanical vibrations to the patient can interfere with the mechanical sensing of atrial contractions. This can result in loss of AV synchrony.

**Multiple devices** – The use of deactivated Micra devices in situ and an active Micra device, or an active transvenous pacemaker or defibrillator, has not been clinically tested to determine whether EMI or physical interaction is clinically significant. Bench testing supports that implantation of an active Micra device, or an active transvenous pacemaker or

defibrillator, next to an inactivated Micra device is unlikely to cause EMI or physical interaction. Post-approval studies are planned to characterize risks of co-implanted, deactivated Micra devices. Currently recommended end of device life care for a Micra device may include the addition of a replacement device with or without explantation of the Micra device, which should be turned off.

**Pacing thresholds following external defibrillation** – Higher pacing threshold can develop following external defibrillation. Higher pacing thresholds can cause loss of capture.

**Patient's age and medical condition** – The patient's age and medical condition should be considered by physicians and patients as they select the pacing system, mode of operation, and implant technique best suited to the individual.

**Prosthetic tricuspid valve** – Use caution when implanting a Micra AV device in a patient with a prosthetic tricuspid valve to avoid valve damage. During device implant, visualizing the prosthetic valve using the LAO fluoroscopic view can aid in limiting interaction with the valve leaflets.

**Steroid use** – It has not been determined whether the warnings, precautions, or complications usually associated with injectable dexamethasone acetate apply to the use of this highly localized, controlled-release device. For a list of potential adverse effects, refer to the Physicians' Desk Reference.

**Temporary pacing** – For patients with left bundle branch block: recognition of the inherent risk of complete heart block related to catheter and lead manipulation in the right ventricle is important. Consider insertion of temporary pacing capabilities before a Micra implant.

**Temporary high-rate pacing** – High-rate stimulation of the ventricle can result in ventricular tachycardia or fibrillation. Temporary high-rate pacing should be applied only under careful patient monitoring and control.

**Right ventricular apical pacing** – Right ventricular apical pacing may be associated with an increased risk of atrial fibrillation, left ventricular dysfunction, and congestive heart failure.

**Nursing mothers** – Systemically administered corticosteroids appear in human milk and could suppress growth, interfere with endogenous corticosteroid production, or cause other untoward effects in nursing infants. Owing to the potential for serious adverse reactions in nursing infants from corticosteroids, a decision should be made whether to discontinue nursing or to use the device, taking into account the importance of the device and the drug to the mother.

**Drug component description** – The active ingredient in the device electrode is dexamethasone acetate [9-Fluoro-11 $\beta$ , 17,21-trihydroxy-16 $\alpha$ -methylpregna-1,4-diene-3,20-dione 21-acetate]. The structural formula for this steroid is as follows:

Dexamethasone acetate (DXAC) - C<sub>24</sub>H<sub>31</sub>FO<sub>6</sub>



**Figure 3.** Structure of dexamethasone acetate (DXAC)

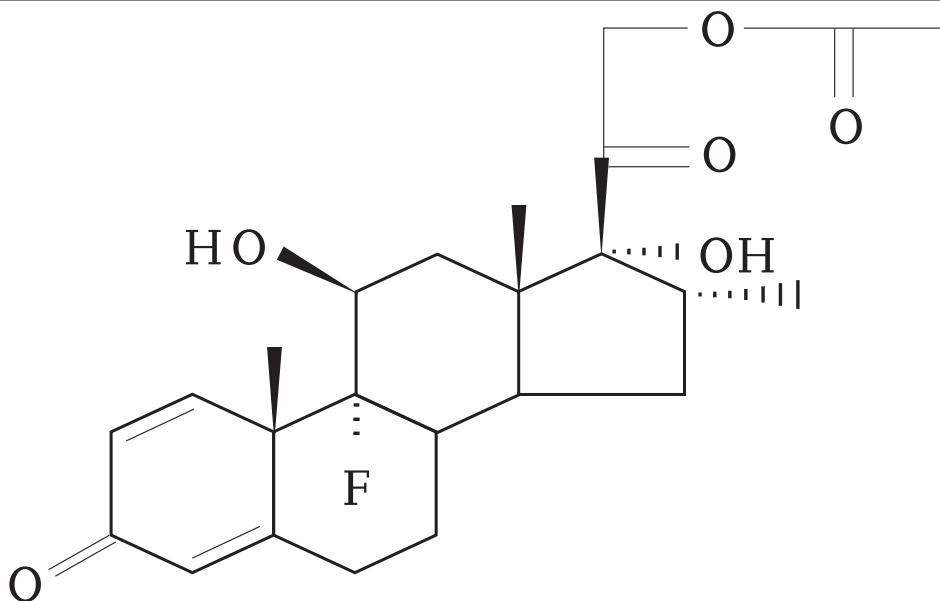

The target dosage of dexamethasone acetate in this device is 272 µg.

**Cautions:**

- Drug interactions of dexamethasone acetate with this device have not been studied.
- Before implanting this device, consider the total patient exposure to dexamethasone acetate.

## 2.2 Explant and disposal under care

Consider the following information about the explant and disposal of the device:

**End of Service (EOS)** – The Micra AV device is not intended to be removed following the End of Service (EOS) condition.

**Note:** Removal of the Micra AV device may be difficult because of its deeper implant site in the heart and the development of fibrotic tissue. If removal of the device is required, refer the patient to a medical center that has expertise in the removal of implanted leads (particularly with cardiac surgery backup) or call a Medtronic representative for more information.

**Return mailer kits** – Contact Medtronic for return mailer kits to return explanted devices for analysis and disposal. See the back cover for addresses.

## 2.3 Explant and disposal postmortem

**Postmortem** – The Micra AV device is not intended to be explanted postmortem. If the device is subjected to cremation, no technical difficulties or significant emissions are expected. In some countries, explanting battery-operated implantable devices postmortem is mandatory because of environmental concerns. Check the local regulations about battery-operated implantable devices and environmental disposal laws.

**Device malfunction** – If the Micra AV device is removed because of a malfunction, return it to Medtronic for analysis and disposal. Use the Product Information Report to return explanted devices. See the back cover of this manual for Medtronic phone numbers and mailing addresses.

Medtronic implantable devices are intended for single use only. Do not resterilize and reimplant explanted devices.

## 2.4 Handling and storage instructions

Carefully observe these guidelines when handling or storing the device.

### 2.4.1 Device handling

**Checking and opening the package** – Before opening the sterile pouch, which is the sterile barrier, visually check for any signs of damage that might invalidate the sterility of the package contents.

**Dropped device** – Do not implant the device if it is dropped on a hard surface from a height of 30 cm (12 in) or more after it is removed from its packaging.

**If the package is damaged** – The device packaging consists of a sterile barrier pouch, aseptic tray, retainer cover, and protective clamshell. If the sterile barrier pouch is wet, punctured, opened, or damaged, do not use the device or delivery catheter system. If any information on the outer package or the sterile package is defaced or damaged so that the information is illegible, do not use the device or delivery catheter system. Return the device and delivery catheter system to Medtronic because the integrity of the sterile packaging or the device functionality might be compromised. This device and delivery catheter system are not intended to be resterilized.

**If the printed manual is illegible** – If this manual is supplied in its printed form and any part of it is illegible, contact a Medtronic representative to request a replacement manual.

**Sterilization** – Medtronic has sterilized the package contents with ethylene oxide before shipment. This product is for single use only and is not intended to be resterilized.

**Device temperature** – Allow the device to reach room temperature before it is programmed or implanted. Device temperature above or below room temperature may affect initial device function.

**Handle with care** – When handling the transcatheter pacing system, do not allow the delivery catheter to whip the implantable device against hard surfaces. If this action occurs inside or outside of the sterile field, do not implant the device.

**Handling the steroid tip** – Avoid reducing the amount of steroid available before implanting the device. Reducing the available amount of steroid may adversely affect low-threshold performance.

Do not allow the electrode surface to come into contact with surface contaminants.

**Device fixation tines** – Do not retract the device fixation tines all the way into the device cup until you are ready to insert the delivery catheter system into the introducer. Unlike the helix electrode of an active fixation lead, the device tines do not require pre-implant exercise. Excessively retracting the device tines into the device cup before implant could adversely affect their fixation performance.

**“Use by” date** – Do not implant the device after the “Use by” date because the battery longevity could be reduced.

**Single use** – This product is intended for single use only. Do not resterilize and re-implant the explanted product.

## 2.4.2 Device storage

**Avoid magnets** – To avoid damaging the device, store the device in a clean area away from magnets, kits containing magnets, and any sources of electromagnetic interference.

**Temperature limits** – Store the transcatheter pacing system package at 25°C (77°F). Excursions from this storage temperature are permitted in the range of 15 to 30°C (59 to 86°F). See the United States Pharmacopeia (USP) Controlled Room Temperature. According to USP excursion conditions, transient spikes up to 40°C (104°F) are permitted, as long as they do not exceed 24 hours.

## 2.5 Device operation

**Accessories** – Use this device only with accessories, parts subject to wear, and disposable items that have been tested to technical standards and found safe by an approved testing agency.

**Battery depletion** – Carefully monitor device longevity by checking battery voltage and replacement indicators. Battery depletion eventually causes the device to stop functioning.

**Device status indicators** – If any of the device status indicators (for example, Electrical Reset) are displayed on the programmer after interrogating the device, inform a Medtronic representative immediately. If these device status indicators are displayed, therapies may not be available to the patient.

**Elective Replacement Indicator (ERI)** – The programmer displays the ERI indicator when the device battery reaches the ERI condition. When the ERI indicator is displayed, implant a new device immediately.

**Electrical reset** – Electrical reset can be caused by exposure to temperatures below  $-18^{\circ}\text{C}$  ( $0^{\circ}\text{F}$ ) or strong electromagnetic fields. Advise patients to avoid strong electromagnetic fields. Observe temperature storage limits to avoid exposure of the device to cold temperatures. If a partial reset occurs, pacing resumes in the programmed mode with many of the programmed settings retained. If a full reset occurs, the device operates in VVI mode at 65 bpm. Electrical reset is indicated by a programmer warning message that is displayed immediately upon interrogation. To restore the device to its previous operation, it must be reprogrammed. Inform a Medtronic representative if your patient's device has reset.

**End of Service (EOS) indicator** – The programmer displays an EOS indicator when the device battery no longer has adequate capacity to provide therapy to the patient and the device has reached the End of Service condition. When the battery reaches the EOS condition, the device deactivates pacing permanently.

**Longevity estimate near RRT** – As the device approaches the RRT condition, the longevity estimate is not updated during a programming session. It is instead updated every day at 00:00 (midnight). These daily longevity estimates can be incorrect if the pacing burden changes significantly for the patient.

**Pacing and sensing safety margins** – Provide an adequate safety margin when selecting values for pacing amplitude, pacing pulse width, and sensitivity parameters.

**Programmers** – Use only Medtronic programmers and application software to communicate with the device. Programmers and software from other manufacturers are not compatible with Medtronic devices.

**Rate-responsive mode** – Do not program the rate-responsive mode for patients who cannot tolerate rates above the programmed Lower Rate. The rate-responsive mode may cause discomfort for those patients.

**Recommended Replacement Time (RRT) indicator** – The programmer displays the RRT indicator when the device battery reaches the RRT condition. If the programmer displays the RRT indicator, schedule an appointment with the patient to implant a new device.

**RV Capture Management** – RV Capture Management does not adjust ventricular output to a value greater than 5.0 V.

**Shipping values** – Do not use shipping values or nominal values for pacing amplitude and sensitivity without verifying that the values provide adequate safety margins for the patient.

### 2.5.1 Pacemaker-dependent patients

**Manual sensing test** – Before starting the sensing test, select a temporary pacing rate that is likely to allow intrinsic sensed events and may be well tolerated by the patient. If the patient shows poor tolerance to the selected pacing rate when the test is in progress, tap **STOP** to stop the test. To complete this test, the device must detect 2 consecutive ventricular sensed

events with an interval of at least 500 ms (a heart rate of 120 bpm or slower) between them. If such an interval is not identified after 10 s, the device stops the test. If a pacing rate suitable to the patient is not available to select, consider omitting the sensing test from the device measurement tests.

See the Micra AV SW044 Programming Guide for more information.

## 2.6 Warnings, precautions, and guidance for clinicians performing medical procedures on cardiac device patients

This section is intended for physicians and other health care professionals who perform medical procedures on patients with Medtronic implanted transcatheter pacemakers and who consult with the patients' cardiologists. This section provides warnings, precautions, and guidance related to medical therapies and diagnostic procedures that may cause serious injury to a patient, interfere with a Medtronic implanted transcatheter pacemaker, or permanently damage the device. This section also lists some common medical procedures that pose no risk.

For guidance on medical procedures that are not addressed in this section, contact your Medtronic representative.

The following table defines the acceptability for EMI from medical procedures and equipment to patients with a Medtronic Micra AV transcatheter pacemaker.

**Table 2.** Acceptability of medical equipment and procedures for patients with an implanted transcatheter pacemaker

Acceptability	Acceptability criteria
<b>Acceptable</b>	The equipment and procedure have a low potential for EMI with an implanted device, and they are safe if the equipment is in proper working condition and used as intended.
<b>Acceptable with precautions</b>	The equipment and procedure have some potential for EMI with an implanted device. You can mitigate the effects of the EMI if the equipment is in proper working condition and used as intended, and if you follow the precautions in this document.
<b>Not recommended</b>	The equipment and procedure have a high potential for EMI with an implanted device, and they are not safe. You cannot mitigate the effects of the EMI.

**Note:** The off-label use of any medical equipment or procedure described in this document voids these acceptability criteria.

### 2.6.1 Ablation

There are 2 types of ablation: cryogenic ablation and radiofrequency (RF) or microwave ablation.

**Cryogenic ablation – Acceptable.** Cryogenic ablation is indicated for the treatment of atrial fibrillation. This procedure creates lesions in the cardiac tissue near the pulmonary veins with cryothermal energy (pressurized liquid nitrous oxide).

**Radiofrequency (RF) or microwave ablation – Acceptable with precautions.** RF or microwave ablation is a surgical technique in which energy creates heat to destroy cells. Common types of ablation include, but are not limited to, intracardiac ablation and endometrial ablation.

RF or microwave ablation used for cardiac device patients can result in, but is not limited to, ventricular tachyarrhythmias, oversensing, unintended tissue damage, or unintended device function.

Observe the following precautions when you administer RF or microwave ablation to a patient with a transcatheter pacemaker:

- Make sure that temporary pacing and defibrillation equipment is available.
- Avoid direct contact between the ablation catheter and the implanted system.
- Consider using at least 2 methods to monitor the patient during ablation. These methods can include arterial pressure display, ECG, manual monitoring of patient rhythm (taking pulse), ear or finger pulse oximetry, or Doppler pulse detection.

### 2.6.2 Capsule endoscopy

**Contact Medtronic Technical Services.** Capsule endoscopy, also known as *video capsule endoscopy*, uses an ingestible digital camera that captures a video record of the patient's digestive tract. The camera is in a capsule with light-emitting diodes, a battery, and a transmitter. Transmission of the video data occurs in short bursts of radiofrequency energy, approximately 2 per s, for an 8-hour diagnostic period.

**Note:** Contact Medtronic Technical Services to confirm that your capsule endoscopy system is safe for your patient.

### 2.6.3 Dental equipment

**Acceptable with precautions.** Dental procedures that use equipment such as apex locators, ultrasonic scalers, drills, and pulp testers, pose no potential for EMI with an implanted transcatheter pacemaker.

Accessories, such as office pillows or headrests, can contain magnets that can affect sensing in an implanted transcatheter pacemaker. Keep an implanted transcatheter pacemaker at least 15 cm (6 in) from these magnets.

**Note:** See “Electrosurgery” for guidance with electrosurgery used in periodontal surgery.

#### **2.6.4 Diagnostic radiology (CT scans, fluoroscopy, mammograms, x-rays)**

Diagnostic radiology includes the following procedures: computerized axial tomography (CT or CAT scan), fluoroscopy, mammograms, and x-rays.

Normally, the accumulated dose of radiation from diagnostic radiology is insufficient to damage an implanted transcatheter pacemaker. If the implanted transcatheter pacemaker is not directly in the radiation beam, there is no potential for EMI, except where noted here.

**CT scan – Acceptable with precautions.** Oversensing can occur only when the implanted transcatheter pacemaker is directly in the CT scan beam.

**Fluoroscopy at < 1 cGy/min – Acceptable.** Fluoroscopy at < 1 cGy/min generates insufficient EMI to affect an implanted transcatheter pacemaker.

**Fluoroscopy at ≥ 1 cGy/min – Not recommended.** EMI from fluoroscopy at ≥ 1 cGy/min can cause oversensing in an implanted transcatheter pacemaker.

**Mammography – Acceptable.** Mammography generates insufficient EMI to affect an implanted transcatheter pacemaker.

**X-ray – Acceptable.** X-rays generate insufficient EMI to affect an implanted transcatheter pacemaker.

#### **2.6.5 Diagnostic ultrasound**

**Acceptable.** Diagnostic ultrasound is an imaging technique that visualizes muscles and internal organs, their size, structures, and motion, as well as any pathological lesions. It can also monitor a fetus, and it can detect and measure blood flow. Diagnostic ultrasound generates insufficient EMI to affect an implanted transcatheter pacemaker. For precautions about therapeutic ultrasound, see “Diathermy (3 types)”.

#### **2.6.6 Diathermy (3 types)**

Diathermy involves the therapeutic heating of body tissues. There are 3 types of diathermy: shortwave diathermy, microwave diathermy, and ultrasonic diathermy, also known as therapeutic ultrasound. Shortwave diathermy or microwave diathermy can cause serious injury, or they can damage an implanted transcatheter pacemaker. Do not use shortwave diathermy or microwave diathermy. Ultrasonic diathermy is acceptable with precautions.

**Shortwave diathermy – Not recommended.** Shortwave diathermy can cause serious patient injury. It can damage an implanted transcatheter pacemaker. Do not perform shortwave diathermy on patients who have an implanted transcatheter pacemaker.

**Microwave diathermy – Not recommended.** Microwave diathermy can cause serious patient injury. It can damage an implanted transcatheter pacemaker. Do not perform microwave diathermy on patients who have an implanted transcatheter pacemaker.

**Therapeutic ultrasound – Acceptable with precautions.** Therapeutic ultrasound (including physiotherapy, high intensity therapeutic ultrasound, and high intensity focused

ultrasound) uses ultrasound at higher energies than diagnostic ultrasound to bring heat or agitation into the body. Therapeutic ultrasound does not produce EMI fields capable of inducing significant energy levels; however, the mechanical energy can physically damage internal device components.

Therapeutic ultrasound is acceptable with a minimum separation distance of 15 cm (6 in) between the applicator and the implanted transcatheter pacemaker. Also, point the ultrasonic beam away from the device.

### 2.6.7 Electrolysis

**Acceptable with precautions.** Electrolysis permanently removes hair by inserting an electrified needle (AC or DC) into the hair follicle. Electrolysis introduces electrical current into the body, which can cause oversensing. Patients should consult with their clinicians to determine if their cardiac condition allows them to undergo electrolysis.

To mitigate the effects of EMI during electrolysis, consider programming asynchronous pacing.

### 2.6.8 Electrosurgery

**Acceptable with precautions.** Electrosurgery (including electrocautery, argon plasma coagulation, electrosurgical cautery, advanced energy surgical technology, and hyfrecator) uses an electric probe to control bleeding, cut tissue, or remove unwanted tissue.

Electrosurgery performed on patients with an implanted transcatheter pacemaker can result in, but is not limited to, the following complications:

- Potential pacing interruption during and up to 5 s immediately after exposure to electrosurgery
- Oversensing
- Unintended tissue damage
- Tachyarrhythmias
- Device damage
- Device malfunction

If electrosurgery is required, consider the following precautions:

- Ensure that temporary pacing and defibrillation equipment is immediately available.
- If possible, use a bipolar electrosurgery system or advanced energy surgical technology. If a unipolar electrosurgery system is used, position the return electrode patch so that the electrical current pathway passes no closer than 15 cm (6 in) from the device. Contact Medtronic Technical Services for further guidance with unipolar electrosurgery.
- Use short, intermittent, and irregular bursts at the lowest clinically appropriate energy levels.
- Always monitor the patient during electrosurgery. If the ECG tracing is not clear due to interference, manually monitor the patient's rhythm (take pulse); alternatively, monitor by some other means such as ear or finger pulse oximetry, Doppler pulse detection, or arterial pressure display.



## 2.6.9 External defibrillation and cardioversion

**Acceptable with precautions.** External defibrillation and cardioversion are therapies that deliver an electrical shock to the heart to convert an abnormal heart rhythm to a normal rhythm.

Medtronic transcatheter pacemakers are designed to withstand exposure to external defibrillation and cardioversion. While damage to an implanted transcatheter pacemaker from an external shock is rare, the probability increases with increased energy levels. These procedures can also temporarily or permanently elevate pacing thresholds or temporarily or permanently damage the myocardium.

Follow these precautions when you deliver external defibrillation or cardioversion:

- Use the lowest clinically appropriate energy.
- Position the patches or paddles at least 15 cm (6 in) from the implanted transcatheter pacemaker.
- Use a Medtronic programmer or a Medtronic device manager to evaluate the implanted transcatheter pacemaker if you deliver external defibrillation or cardioversion.

## 2.6.10 Hearing aids

This section describes 2 types of hearing aids that can be used by patients with transcatheter pacemakers.

### Hearing aids and cochlear implants, in ear or hardwired

**Acceptable.** – Hearing aids or cochlear implants worn in the ear or hardwired to an acoustical detector have no potential for EMI with an implanted transcatheter pacemaker.

### Hearing aids with transmitting loop antenna

**Acceptable with precautions.** – A hearing aid with a transmitting loop antenna, worn around the neck, radiates a magnetic field that is coupled with the T-coil in the earpiece. Advise patients to keep the loop antenna at least 15 cm (6 in) from an implanted transcatheter pacemaker.

If the loop antenna is closer than 15 cm (6 in) to a transcatheter pacemaker, there is potential for pacing inhibition.

Advise patients to reposition the loop antenna to the shoulder opposite the implant site. If that is not possible, advise patients to use an alternative transmitting antenna that can be worn at least 15 cm (6 in) from the implanted device.

**Note:** This precaution also applies to transmitting loop antennae attached to audio equipment.

**Note:** Bluetooth hearing aids without a transmitting loop are acceptable.

### 2.6.11 Hyperbaric therapy (including hyperbaric oxygen therapy, or HBOT)

**Acceptable with precautions.** Hyperbaric therapy is the medical use of air or 100% oxygen at a higher pressure than atmospheric pressure. Hyperbaric therapy treats several conditions, including decompression sickness, carbon monoxide poisoning, serious infections, and persistent wounds. Hyperbaric therapies with pressures exceeding 4.0 ATA, approximately 30 m (100 ft) of seawater, can affect the function of or damage an implanted transcatheter pacemaker. To avoid or mitigate risks to an implanted transcatheter pacemaker, do not expose patients to pressures exceeding 4.0 ATA.

### 2.6.12 Lithotripsy

**Acceptable with precautions.** Lithotripsy uses mechanical shock waves to break up kidney stones or gallbladder stones. Lithotripsy can damage an implanted transcatheter pacemaker if it is at the focal point of the lithotripter beam. Keep the focal point of the lithotripter beam at least 2.5 cm (1 in) away from the implanted transcatheter pacemaker.

### 2.6.13 Magnetic resonance imaging (MRI)

A Medtronic Micra AV implanted transcatheter pacemaker is **MR Conditional**.

Use any of the following resources to confirm that the Medtronic Micra AV transcatheter pacemaker is MR Conditional:

- See the Medtronic MR Conditional Product Search for Cardiac Devices at [www.medtronic.com/mrc](http://www.medtronic.com/mrc).
- See the Medtronic MRI Resource Library at <http://manuals.medtronic.com/manuals/mri/region>.
- If you are in the USA, you can call +1 877 674 7677 for MRI technical consultation.
- If you are outside of the USA, you can contact a Medtronic representative for MRI technical consultation.

Patients with an implanted Medtronic Micra AV transcatheter pacemaker can undergo an MRI scan under specified conditions. For details, refer to the Medtronic Micra AV MRI technical manual, or contact the listed Medtronic resources.

### 2.6.14 Stereotaxis

**Acceptable with precautions.** Stereotaxis allows clinicians to steer catheter-based diagnostic and therapeutic devices throughout the body by using magnetic navigation. During a stereotaxis procedure, the magnetic field can cause interference to the device. The implanted transcatheter pacemaker resumes normal programmed operation after the stereotaxis procedure.

Clinicians should consult with cardiologists to determine if a stereotaxis procedure is safe for their patients with an implanted transcatheter pacemaker.

## 2.6.15 Therapeutic radiation (radiosurgery and radiotherapy)

**Radiosurgery – Acceptable with precautions.** Also known as stereotactic radiosurgery, radiosurgery delivers intense doses of radiation from a linear accelerator to destroy tumors with submillimeter precision.

Do not subject an implanted transcatheter pacemaker to direct radiosurgery exposure. Accumulated radiation dosage must not exceed 500 cGy.

**Radiotherapy – Acceptable with precautions.** Radiotherapy is a cancer treatment that uses radiation to control cell growth and destroy tumors. Types of radiotherapy include high-energy photon radiation and proton beam therapy (PBT).

Do not subject an implanted transcatheter pacemaker to direct radiotherapy exposure. Accumulated radiation dosage must not exceed 500 cGy.

**Note:** Contact your Medtronic representative for additional guidance to monitor the implanted transcatheter pacemaker during radiosurgery or radiotherapy.

**Transcatheter pacemaker shielding and radiation modeling** – Discuss a shielding plan with the radiation oncologist and physicist responsible for treating the patient. The plan includes modeling of the radiation to be absorbed by the implanted transcatheter pacemaker — the accumulated radiation dosage must not exceed 500 cGy.

**Transcatheter pacemaker interference from radiosurgery or radiotherapy** – If a patient undergoes radiosurgery or radiotherapy, an implanted transcatheter pacemaker can sense direct or scattered radiation as cardiac activity for the duration of the procedure. Average dose rates at the transcatheter pacemaker of less than 1 cGy/min are unlikely to produce transcatheter pacemaker interference. Decreasing the dose rate (for example, by increasing the distance between the beam and the implanted transcatheter pacemaker) decreases the potential for interference.

The programmer or device manager can detect transcatheter pacemaker interference during the initial therapy, shown as unexpected activity in the programmer Marker Channel or the device manager event markers. If interference does not occur, it is unlikely to occur during future treatments with the same therapy.

**Note:** Interrogate the implanted transcatheter pacemaker to evaluate it following radiosurgery or radiotherapy.

To mitigate the effects of oversensing EMI during therapy, consider programming the device to an asynchronous pacing mode.

**Device reset following radiation** – A device reset (also called an electrical reset) does not indicate damage to the implanted transcatheter pacemaker; however, a reset requires device interrogation. In rare cases, a device reset can occur several days following exposure to radiation.

Report a device reset to Medtronic Technical Services. Download the device data file with your programmer's save-to-media function and include it with your report. This file contains the device memory image.

**Transcatheter pacemaker damage from radiosurgery or radiotherapy** – Radiation can affect electronic circuitry, so an accumulated radiation dosage of > 500 cGy can damage an implanted transcatheter pacemaker. However, radiation damage is sometimes not immediately apparent. If a patient requires radiosurgery or radiotherapy from any source, do not expose an implanted transcatheter pacemaker to an accumulated radiation dosage that exceeds the recommended limit. Record and monitor the accumulated radiation dosage to implanted devices for patients who undergo multiple radiosurgeries or courses of radiation treatment.

Tests have shown damage to implanted Medtronic transcatheter pacemakers with accumulated radiation dosage > 500 cGy. Medtronic therefore cannot predict the operation of implanted transcatheter pacemakers that have withstood radiation overdose. Monitor devices exposed to radiation overdose after each radiosurgery or radiotherapy treatment and consider them for replacement. Consider an augmented follow-up schedule following the completion of all procedures.

**How to evaluate a transcatheter pacemaker for a device reset** – If an implanted transcatheter pacemaker has had a device reset, a device reset warning message displays immediately upon interrogation. Reprogram the device to restore normal operation. Inform your Medtronic representative if your patient's device has reset.

#### **2.6.16 TENS (transcutaneous electrical nerve stimulation)**

**Not recommended.** TENS (including NMES – neuromuscular electrical stimulation) is a pain control technique that uses electrical impulses passed through the skin to stimulate nerves. A TENS device is not recommended for in-home use by cardiac device patients due to a potential for oversensing, inappropriate pacing therapy, inhibition of pacing, or undesired asynchronous pacing. If a TENS device is determined to be medically necessary, contact a Medtronic representative for more information.

#### **2.6.17 TUNA (transurethral needle ablation), TUMT (transurethral microwave therapy), and TURP (transurethral resection of the prostate)**

**Acceptable with precautions.** TUNA, TUMT, and TURP are surgical procedures that treat urinary symptoms caused by benign prostatic hyperplasia (BPH). These procedures use precisely focused energy to ablate prostate tissue. Patients with implanted cardiac devices can conditionally undergo procedures that use a TUNA, TUMT, or TURP system. To avoid affecting an implanted transcatheter pacemaker when performing a TUNA, TUMT, or TURP procedure, position the return electrode on the lower back or lower extremity at least 15 cm (6 in) away from the implanted transcatheter pacemaker.

## 2.7 Warnings, precautions, and guidance related to electromagnetic interference (EMI) for cardiac device patients

Many cardiac device patients resume their normal daily activities after full recovery from surgery. However, there may be certain situations that patients need to avoid. Because a cardiac device is designed to sense the electrical activity of the heart, the device may sense a strong electromagnetic energy field outside of the body and deliver a therapy that is not needed or withhold a therapy that is needed. The following sections provide important information to share with patients about electrical equipment or environments that may cause interference with their implanted cardiac device. For additional guidance about EMI, contact your Medtronic representative.

### 2.7.1 General guidelines for patients in the presence of EMI

Advise patients to observe the following general guidelines in the presence of EMI:

- Area restrictions – Consult with your clinician before entering an area where signs are posted that warn persons with an implanted transcatheter pacemaker.
- Symptoms of EMI – If you become dizzy or feel rapid or irregular heartbeats while using an electrical item, release whatever you are touching or move away from the item. The implanted cardiac device should immediately return to normal operation. If symptoms do not improve when you move away from the item, notify your clinician.
- Proper grounding of electrical items – To avoid interference from electrical current that can leak from improperly grounded electrical items and pass through the body, observe the following precautions:
  - Confirm that all electrical items are properly wired and grounded.
  - Confirm that electrical supply lines for swimming pools and hot tubs are properly installed and grounded according to local and national electrical code requirements.

### 2.7.2 Items with no distance restriction from an implanted transcatheter pacemaker

The following table represents items that, when used as intended and in good working condition, have no distance restriction from an implanted transcatheter pacemaker.

**Table 3.** Examples of household items with no distance restriction for EMI

Bed, adjustable	Garage door opener, remote control	Medical alert necklace or pendant
Battery charger for household batteries	GPS (global positioning system)	Microwave oven
Blender / food processor	Guitar, electric	Radio, AM/FM
Bluetooth technology	Hair shaver / trimmer, battery powered <sup>a</sup>	Refrigerator

**Table 3.** Examples of household items with no distance restriction for EMI (continued)

Can opener	Hair straightener	Remote control, infrared, for CD/DVD player, television, and so on.
CD/DVD/DVR player or recorder, without speakers	Heart rate monitor, chest band	Residential power line
Clothes iron	Heating pad	Satellite dish, receiving
Curling iron	Home security system, infrared or ultrasonic	Sauna, electric
Digital music player (for example, iPod)	Hot tub <sup>b</sup>	Smart scale that measures body mass index (BMI) <sup>c</sup>
Dishwasher	House arrest anklet <sup>d</sup>	Stove, kitchen <sup>e</sup>
Electric blanket or electric mattress pad	Ionized bracelet	Swimming pool <sup>b</sup>
Electronic weight scale	Kiln, 115-120 V AC or 220-240 V AC	Television <sup>f</sup>
Flashlight	Massage bed / chair / pad	Toaster

<sup>a</sup> Compare to hair shaver / trimmer in Table 8, page 32.

<sup>b</sup> Hot tub and swimming pool must be properly grounded.

<sup>c</sup> Contact Medtronic Technical Services for a list of acceptable BMI scales.

<sup>d</sup> Compare to house arrest bracelet. See Table 6, page 31.

<sup>e</sup> 60 cm (24 in) distance restriction from induction cooktops.

<sup>f</sup> Maintain a 15 cm (6 in) distance from television speakers.

**Table 4.** Examples of professional and vocational items with no distance restriction for EMI

Anti-theft detection pedestals / electronic article surveillance equipment for retail loss prevention <sup>a</sup>	Diesel engines	Office printer
Automobiles, electric <sup>b</sup>	Facsimile (fax) machine	Photocopier / copy machine
Automobiles, hybrid <sup>c</sup>	Hooded hair dryer, salon <sup>d</sup>	Pager, receiver only
Barcode scanner	Laser level, battery operated	Soldering iron <sup>e</sup>
Calipers, battery powered	Office calculator	Stud finder, battery operated

<sup>a</sup> Safe when walking between the pedestals at normal walking speed. Do not linger near the detection equipment.

<sup>b</sup> 30 cm (12 in) distance from electric automobile battery charger.

<sup>c</sup> Compare to hybrid automobiles in Section 2.7.5, "Vehicles with engines fueled by gasoline or petrol", page 34.

<sup>d</sup> Compare to hair dryer, handheld in Table 6, page 31.

<sup>e</sup> Compare to soldering gun; see Table 11, page 34.

**Table 5.** Examples of recreational items with no distance restriction for EMI

Casino slot machine	Motorcycle vest, heated	Tanning booth, electrostatic
Electric golf cart <sup>a</sup>	Tanning bed	

<sup>a</sup> Maintain a 15 cm (6 in) distance from battery while charging.

### 2.7.3 Items with a 15 cm (6 in) distance restriction from an implanted transcatheter pacemaker

The following table represents items that, when used as intended and in good working condition, have a 15 cm (6 in) distance restriction from an implanted transcatheter pacemaker.

**Table 6.** Examples of household items with 15 cm (6 in) distance restriction from an implanted transcatheter pacemaker

Air filter, ionized	Magnet, small	Static electricity generator, “plasma ball” <sup>a</sup>
Amateur radio, ham radio, and marine radio, < 3 W, from antenna	Magnetic back brace or belt	Stereo speakers, from magnet
Canine shock collar for electric pet containment fence, including remote control and base with antenna	Magnetic cover for tablet computer	Television audio headset, from transmitter near television
Clasp, magnetic	Magnetic chair pad	Tools, battery powered
Electric guitar speakers	Magnetic therapy products	Tools, small electric, from motor
Electric kitchen appliances, handheld	Massager, handheld	Toothbrush, electric, from charging base
Exercise bicycle, wheel magnet	Model cars, airplanes, video drones — remote controlled, from controller antenna	Toy train, electric, from transformer and rails
Hair dryer, handheld <sup>b</sup>	Refrigerator door, from magnetic closure strip	Treadmill, from electric motor

**Table 6.** Examples of household items with 15 cm (6 in) distance restriction from an implanted transcatheter pacemaker (continued)

Home security system, microwave, from transmitter	Sewing machine or serger, from motor	Ultrasonic or radio frequency pest control device
House arrest bracelet <sup>c</sup>	Smart meter (used by utility companies)	Vacuum cleaner, from motor

<sup>a</sup> Do not touch this item.

<sup>b</sup> Compare to hooded hair dryer, salon in Table 4, page 30.

<sup>c</sup> Compare to house arrest anklet; see Table 3, page 29.

**Table 7.** Examples of household wireless electronic devices with 15 cm (6 in) distance restriction from an implanted transcatheter pacemaker

Activity band or wearable fitness monitor, if device contains magnets	Earbuds, wireless (from magnet)	Remote control, radiofrequency (RF), for CD/DVD player, television, and so on
Cellular adaptor for laptop computer	eReader	Remote keyless entry and remote car starter key fob
Computer keyboard, wireless	Gaming console and controllers	Radiofrequency (RF) wireless charger
Computer: personal, laptop, or tablet	Headphones, from magnets	Smart watch
Cordless telephone, < 3 W, from antenna and base station <sup>a</sup>	Network router	Wi-Fi or cellular modem, from transmitter/receiver
CD/DVD/DVR player and recorder with speakers	Qi inductive mobile telephone charger	

<sup>a</sup> See also cordless telephone, 3 to 15 W, in Table 10, page 34.

**Caution:** Do not carry a wireless device in a pocket or in a shoulder bag near a transcatheter pacemaker.

**Table 8.** Examples of professional and vocational items with 15 cm (6 in) distance restriction from an implanted transcatheter pacemaker

Badge (name tag) with magnetic clasp	OnStar Technology, from antenna	Tools, handheld battery powered, from battery while charging
Badge (security) with externally activated electronic circuit	Pager, 2-way, ≤ 3 W, from antenna	Tools, handheld electric, from motor
Citizens band (CB) radio, ≤ 3 W, from antenna	Personal scooter / electric grocery cart, from battery while charging	Security badge wall scanner



**Table 8.** Examples of professional and vocational items with 15 cm (6 in) distance restriction from an implanted transcatheter pacemaker (continued)

Cordless microphone, from transmitter	Piconet wireless computer connector, from antenna	Tattoo machine
Extractor wand, for automobile mechanics	Portable radio (walkie-talkie), ≤ 3 W, from antenna	Telephone headset, cordless
Hair shaver / trimmer, corded <sup>a</sup>	—	—

<sup>a</sup> Compare to hair shaver / trimmer, battery powered in Table 3, page 29.

<b>Mobile telephones</b>
Keep mobile telephones, cellular telephones, or smartphones at least 15 cm (6 in) from an implanted transcatheter pacemaker.
Keep magnetic accessories for mobile telephones at least 15 cm (6 in) from an implanted transcatheter pacemaker. Accessories with magnets can include wireless earbuds, plug-in earbuds, or cases with magnetic clasps.

**Table 9.** Sample of recreational items with 15 cm (6 in) distance restriction from an implanted transcatheter pacemaker

Bingo wand	Golf cart, electric, from battery while charging	Marine radio, < 3 W, from antenna
Disney MagicBand reader <sup>a</sup>	Laser tag, from magnet or transmitter in some vests	

<sup>a</sup> No distance restriction for Disney MagicBand.

### 2.7.4 Items with a 30 cm (12 in) distance restriction from an implanted transcatheter pacemaker

The following table represents items that, when used as intended and in good working condition, have a 30 cm (12 in) distance restriction from an implanted transcatheter pacemaker.

**Table 10.** Examples of household items with 30 cm (12 in) distance restriction from an implanted transcatheter pacemaker

Amateur radio, cordless telephone <sup>a</sup> , ham radio, or 2-way portable radio, 3 to 15 W, from antenna and base station	Automobile battery charger / charging station for electric automobiles	Lawn and garden tools powered by gasoline / petrol, from ignition system (for example, backpack leaf blowers, snow blowers, chainsaws)
Automobile battery charger for gasoline engines	Electrical transformer / transformer box, residential	

<sup>a</sup> Compare to cordless telephone, < 3 W, in Table 7, page 32.

**Table 11.** Examples of professional and vocational items with 30 cm (12 in) distance restriction from an implanted transcatheter pacemaker

Cattle prod / stock prod, from electrodes	Marine radio, 3 to 15 W, from antenna	Transmitters, portable 3 to 15 W, from antenna
Degausser / demagnetizer	Pagers, 2-way, 3 to 15 W, from antenna	UPS (uninterruptible power source – commercial power failure back-up system) up to 200 A
Generators, electric, portable AC/DC, up to 20 kW	Soldering gun <sup>a</sup>	

<sup>a</sup> Compare to soldering iron, see Table 4, page 30.

### 2.7.5 Vehicles with engines fueled by gasoline or petrol

Observe the following precautions when using vehicles fueled with gasoline / petrol:

- Do not repair or perform maintenance work on an engine while it is running or when its ignition switch is on. Repair or perform maintenance work on an engine when both the engine and its ignition switch are off.
- Maintain a 30 cm (12 in) distance between the implanted device and an engine that is running or that has its ignition switch turned on.

**Note:** Diesel engines are safe for patients with an implanted transcatheter pacemaker.

**Table 12.** Examples of vehicles with gasoline / petrol engines with a 30 cm (12 in) distance restriction from an implanted transcatheter pacemaker

All-terrain vehicle (ATV)	Equipment / vehicles used for agriculture or construction	Motorcycle
Automobile / hybrid automobile <sup>a</sup>	Forklift – also fueled by propane or natural gas	Snowmobile or snow machine
Boat motor	Jet ski	Truck / lorry

<sup>a</sup> Automobile / hybrid automobile have no distance restriction for drivers or passengers.

### 2.7.6 Items with a 60 cm (24 in) distance restriction from an implanted transcatheter pacemaker

The following table represents items that, when used as intended and in good working condition, have a 60 cm (24 in) distance restriction from an implanted transcatheter pacemaker.

**Table 13.** Examples of items with a 60 cm (24 in) distance restriction from an implanted transcatheter pacemaker

<b>Household items</b>	
Amateur radio, ham radio, or walkie-talkie, 15 to 30 W, from antenna	Stove, induction cooktop
Jumper cables, during use	Residential satellite dish, 2-way
<b>Professional and vocational items</b>	
Anti-theft tag deactivator	GPS survey equipment
Bench-mounted / free-standing tools with motors ≤ 400 horsepower	Radio transmitters, vehicle-mounted, 15 to 30 W – from antenna
Forklift, battery powered, from motor	Welding equipment with less than 160 A (see Section 2.7.7)
<b>Recreational items</b>	
Beach comber / metal detector, from detector head	Marine radio, single side band, 20–25 W, from antenna

### 2.7.7 Items and environments with special considerations for EMI for patients with implanted transcatheter pacemakers

The information in this section discusses electrical equipment and environments that generate EMI that can affect an implanted transcatheter pacemaker. Share this information with patients who work with this equipment or in these environments, or who can encounter these sources of EMI. Contact Medtronic Technical Services for additional guidance regarding these environments.

**Industrial equipment** – The following industrial equipment and environments include high-voltage current, magnetic fields, or other EMI sources that can affect device operation. Patients may need to avoid using or working near the following categories of industrial equipment. Medtronic recommends that the employers of patients with transcatheter pacemakers consult with clinicians before their employees return to work in these environments.

- Electric furnaces used in the manufacturing of steel
- Induction heating equipment and induction furnaces, such as kilns
- Industrial magnets such as those used in surface grinding and electromagnetic cranes
- Dielectric heaters to heat plastic and dry glue in furniture manufacturing
- Electric arc and resistance welding equipment operating at greater than 160 A (see Table 13, page 35 for guidance with welding equipment operating at less than 160 A)
- Broadcasting antennas for AM, FM, shortwave radio, and TV stations
- Microwave transmitters
- Power plants, power generators, and transmission power lines

**Note:** Lower-voltage distribution power lines for homes and businesses are unlikely to affect implanted cardiac devices.

### **Anti-theft and security systems**

**Anti-theft systems** – Anti-theft systems are unlikely to affect an implanted transcatheter pacemaker. However, as a precaution, do not linger near or lean against these systems. Walk past or through them at a normal pace. If you experience symptoms, move away from the equipment. After you move away from the equipment, the device resumes its previous state of operation.

**Security systems** – Metal detectors (walk-through archways and handheld wands) and full-body imaging scanners (millimeter wave scanners, three-dimensional imaging scanners, or backscatter full body scanners) are unlikely to affect an implanted transcatheter pacemaker. These detectors and scanners are common in airports, courthouses, and other high-security facilities.

When you encounter security systems, observe the following guidelines:

- Always carry your cardiac device ID card. If your cardiac device sets off a metal detector or a security system, your card is helpful for security staff.
- To minimize the risk of temporary interference with your implanted transcatheter pacemaker while going through the security screening process, do not touch metal surfaces around any screening equipment.
- Do not stop or linger in a walk-through archway; simply walk through the archway at a normal pace.
- If a handheld wand is used, ask the security operator not to hold it over or wave it back and forth over your implanted transcatheter pacemaker.
- If you have concerns about security screening methods, show your cardiac device ID card to the security operator, request alternative screening, and then follow the security operator's instructions.

### 2.7.8 Items with low potential for EMI at extended distances from an implanted transcatheter pacemaker

The following table lists communications items that have low potential for EMI when used as intended and in good working condition. These items are safe for patients when their antennae are at, or greater than, the listed distance from an implanted transcatheter pacemaker.

**Note:** These distances assume free space and an unobstructed line-of-sight.

**Table 14.** Items with low potential for EMI at extended distances from an implanted transcatheter pacemaker

<b>Communications</b>	
1 m (3 ft)	2-way portable radio, from antenna – 30 to 50 W.
2 m (6 ft)	2-way portable radio, from antenna – 50 to 125 W.
3 m (9 ft)	Amateur radio, ham radio, marine radio, or 2-way portable radio, from antenna – 125 to 250 W. Cellular tower – ≤ 250 W. Commercial broadcast towers – 125 to 250 W. For transmitters with power levels > 250 W, avoid restricted areas that contain the antenna.
4 m (12 ft)	Amateur or ham radio, from antenna – 250 to 500 W.
6 m (20 ft)	Amateur or ham radio, from antenna – 500 to 1000 W.
9 m (30 ft)	Amateur or ham radio, from antenna – 1000 to 2000 W.

### 2.7.9 Non-EMI environments with special consideration for patients with implanted transcatheter pacemakers

This section includes important information to share with patients about home or work environments that can affect an implanted transcatheter pacemaker. Contact Medtronic Technical Services for additional guidance regarding these environments.

**Note:** Many patients who have a Medtronic Micra AV transcatheter pacemaker can be subjected to mechanical vibrations from devices or environments found in their daily living. External mechanical vibrations can interfere with atrial mechanical sensing in the device. This interference can compromise AV synchrony when the device is pacing in VDD mode.

<b>Air travel</b>
Air travel in a pressurized cabin is safe for patients with an implanted transcatheter pacemaker.

### **High altitude environments and activities**

Medtronic implantable transcatheter pacemakers can withstand air pressure levels equivalent to an altitude limit of 6,000 m (20,000 ft). The following activities are safe for patients with an implanted transcatheter pacemaker:

- Hiking, trekking, skiing or vehicle travel up to the altitude limit.
- Camping or extended stays up to the altitude limit.

### **Rifles, shotguns**

Patients should consult their physician for advice and limitations for the use of rifles and shotguns. A rifle or shotgun should be used on the shoulder that is opposite from the implant location.

### **Scuba diving, recreational diving**

Medtronic implantable transcatheter pacemakers are rated for pressure levels up to 4.0 ATA (atmospheres absolute). 4.0 ATA is approximate to a seawater depth of 30 m (100 ft).

## **2.8 Physician training**

**Implantation and system management** – Implantation and ongoing system management must be performed by individuals trained in the operation and handling of the system and must be in compliance with procedures described in the appropriate technical instructions. Inadequate training or failure to follow instructions may result in harm to the patients.

## **2.9 Potential adverse events**

The following are known potential adverse events associated with the use of this product.

**Note:** Implant and usage of this product may result in adverse events, which may lead to injury, death, or other serious adverse reactions.

- Acute tissue trauma
- Allergic reaction
- Aneurysm
- AV fistula
- Bradyarrhythmia
- Cardiac arrest
- Cardiac inflammation
- Cardiac perforation
- Cardiac tamponade
- Cardiac valve damage
- Coronary sinus dissection
- Device embolization
- Device migration

- Discomfort
- Dizziness
- Dyspnea
- Embolism
- Endocarditis
- Excessive fibrotic tissue growth
- Extracardiac stimulation
- Fever
- General surgery risks and complications from comorbidities, such as hypotension, pneumonia, hypertension, cardiac failure, renal failure, and anemia
- Heart failure decompensation (hospitalization)
- Hematoma
- Hemorrhage
- Hemodynamic compromise
- Hiccups
- Hospitalization
- Impaired cardiac function (due to device)
- Infection
- Lethargy
- Loss of pacing
- Mental anguish
- Necrosis
- Nerve damage
- Oversensing
- Pacemaker syndrome
- Palpitations
- Pericardial effusion
- Pericarditis
- Peripheral ischemia
- Pseudoaneurysm
- Return of cardiac symptoms
- Skeletal muscle sensation/twitching
- Syncope
- Threshold elevation
- Thrombosis
- Toxic reaction
- Undersensing
- Vascular tear
- Vessel dissection
- Vessel perforation
- Wound dehiscence

## 2.10 Adverse events and clinical trial data

Information regarding clinical studies and adverse events related to this device is available at [www.medtronic.com/manuals](http://www.medtronic.com/manuals).

The following clinical studies are related to this device:

**Micra Transcatheter Pacing Study** – This clinical study, which evaluated the safety and efficacy of the Micra transcatheter pacing system, provides support for the system.

**MARVEL (Micra Atrial TRacking Using a Ventricular AccELerometer) 2 Download Study** – This clinical study, which evaluated the performance of atrial mechanical sensing to enable AV synchronous pacing in Micra TPS devices, provides support for VDD pacing in the Micra AV Model MC1AVR1 system.



## 3 Drug information

### 3.1 Mechanism of action

Steroid suppresses the inflammatory response that is believed to cause threshold rises typically associated with implanted pacing electrodes. Dexamethasone acetate is a synthetic steroid of the glucocorticoid family. Glucocorticoids have potent anti-inflammatory actions via direct and indirect effects on major inflammatory cells. Glucocorticosteroids bind to a cytoplasmic glucocorticoid receptor as well as a membrane-bound receptor. Binding to the cytoplasmic receptor leads to receptor activation and translocation to the nucleus. The receptor interacts with specific DNA sequences within the regulatory regions of affected genes. Thus, glucocorticoids inhibit the production of multiple cell factors that are critical in generating the inflammatory response.

### 3.2 Pharmacokinetics and metabolism

**Pharmacokinetics** – The pharmacokinetics (local drug levels and systemic levels) of dexamethasone acetate and its metabolites following implant were not evaluated in human clinical trials. When delivered intra-muscularly, the lipid-soluble dexamethasone acetate is slowly absorbed throughout the tissue.

**Metabolism** – The conversion of dexamethasone acetate to dexamethasone occurs within hours. The dexamethasone alcohol (dexamethasone) is the active glucocorticoid used in this Medtronic device. Steroid is applied via MCRD (Monolithic controlled release device) and eluted to the tissue interface where it will be used. The form of the steroid, whether it is a prodrug or the pharmacologically active dexamethasone, is irrelevant, as the steroid is directly present at the injury site to treat the inflammation. Dexamethasone acetate is hydrolyzed into dexamethasone, which is readily absorbed by the surrounding tissue and body fluids. Glucocorticoids, when given systemically, are eliminated primarily by renal excretion of inactive metabolites.

### 3.3 Mutagenesis, carcinogenicity, and reproductive toxicity

The mutagenesis, carcinogenicity, and reproductive toxicity of the Model MC1AVR1 device have not been evaluated. However, the mutagenesis, carcinogenicity, and reproductive toxicity of dexamethasone acetate have previously been evaluated.

**Mutagenesis** – Genotoxicity evaluation of dexamethasone was undertaken using in vitro and in vivo assays. Analyses of chromosomal aberrations, sister-chromatid exchanges in human lymphocytes, and micronuclei and sister-chromatid exchanges in mouse bone marrow showed dexamethasone to be capable of attacking the genetic material. However, the Ames/Salmonella assay, both with and without S9 mix, did not show any increase His+ revertants.

**Carcinogenicity** – Although adequate and well-controlled animal studies have not been performed on Dexamethasone acetate, use in humans has not shown an increase in malignant disease.

**Reproductive Toxicity** – Adrenocorticoids have been reported to increase or decrease the number and motility of spermatozoa. However, it is not known whether reproductive capacity in humans is adversely affected.

**Pregnancy** – Adrenocorticoids cross the placenta. Although adequate studies have not been performed in humans, there is some evidence that pharmacologic doses of adrenocorticoids may increase the risk of placental insufficiency, decreased birth weights or stillbirth. However, teratogenic effects in humans have not been confirmed.

Infants born to mothers who have received substantial doses of adrenocorticoids during pregnancy should be carefully observed for signs of hypoadrenalism and replacement therapy administered as required.

Prenatal administration of dexamethasone to the mother to prevent respiratory distress syndrome in the premature neonate has not been shown to affect the child's growth or development adversely. Physiologic replacement doses of adrenocorticoids administered for treatment of adrenal insufficiency are also unlikely to adversely affect the fetus or neonate. Animal studies have shown that adrenocorticoids increase the instance of cleft palate, placental insufficiency, spontaneous abortions, and intrauterine growth retardation.

**Lactation** – Problems in humans have not been documented. Adrenocorticoids are excreted in breast milk and may cause unwanted defects such as growth suspension and inhibition of endogenous steroid production in the infant.

# 4 Implant procedure

## 4.1 Preparing for an implant

The following implant procedures are provided for reference only. Proper surgical procedures and sterile techniques are the responsibility of the physician. Each physician must apply the information in these procedures according to professional medical training and experience.

In general, Medtronic recommends that implanting physicians choose the level of anesthesia that minimizes patient risk and is commonly used in their implanting centers. In the clinical trial, sedation has ranged from local anesthesia in the groin to fully intubated, deep central anesthesia.

Ensure that you have all of the necessary instruments, system components, and sterile accessories to perform the implant.

### 4.1.1 Instruments, components, and accessories required for an implant

The following non-implanted instruments and equipment are used to support the implant procedure:

- Medtronic programmer with a Medtronic programming head
- Model SW044 software application
- External defibrillator

**Note:** For patients deemed at a more significant risk of VT or VF, place adhesive defibrillation electrode patches on the patient prior to device implant.

The following sterile system components and accessories are used to perform the device implant:

- Micra AV Model MC1AVR1 transcatheter pacing system, which consists of the implantable device and delivery system
- Sterile programming head sleeve (not required if a sterilized programming head is used for the implant or if the programming head is not used in a sterile field)
- 7.8 mm (23 Fr) introducer sheath that is 56 cm (22 in) long or longer, such as the Medtronic Micra Introducer
- 0.89 mm (0.035 in) stiff guidewire that is 180 cm (70.866 in) long

### 4.1.2 Setting up the programmer and starting the application

For instructions about how to set up the programmer, see the Medtronic programmer reference guide. After you set up the programmer, follow these steps:

- Install the SW044 application software on the programmer.
- Establish telemetry with the device.
- Use the programmer to start a patient session.

**Note:** Electromagnetic interference (EMI) during a telemetry session can interfere with device programming, or it can interfere with the confirmation of device programming. Remove any sources of EMI that can affect the telemetry signal.

### 4.1.3 Warnings and precautions when preparing for the device implant

**Before implanting the MRI SureScan device in a patient, refer to the Medtronic MRI Technical Manual provided for MRI-specific requirements and instructions.**

Review the following information before implanting the device:

**Warning:** Do not allow the patient to have contact with grounded electrical equipment that might produce electrical current leakage during implant. Electrical current leakage may induce tachyarrhythmias that may result in the patient's death.

**Warning:** Keep external defibrillation equipment nearby for immediate use. Potentially harmful spontaneous or induced tachyarrhythmias may occur during device testing, implant procedures, and post-implant testing.

**Caution:** Do not implant the device after the "Use by" date on the package label. Battery longevity could be reduced.

### 4.1.4 How to prepare the device for implant

Before opening the sterile package, perform the following steps to prepare the device for implant:

1. Interrogate the device and print an Initial Interrogation Report.

**Caution:** If the programmer reports that an electrical reset occurred, do not implant the device. Contact a Medtronic representative.

2. Check the Initial Interrogation Report to confirm that the battery voltage is at least 3.0 V at room temperature.

If the device has been exposed to low temperatures, the battery voltage will be temporarily lower. Allow the device to warm to room temperature for at least 48 hours and check the battery voltage again. If an acceptable battery voltage cannot be obtained, contact a Medtronic representative.

**Note:** The device automatically measures the battery voltage once a day at 02:30. The automatic daily measurement of battery voltage is displayed on the Battery and Device Measurements screen.

3. Program the device from the **Device Off** mode to the **VVI** mode.
4. Tap **Params > Data Collection Setup... > Device Date/Time...** to set the internal clock of the device to the correct date and time.
5. Program the pacing parameters to values appropriate for the patient.

**Notes:**

- Do not enable a pacing feature that affects the pacing rate before implanting the device. Doing so may result in an elevated pacing rate that is faster than expected.
  - Patient information is typically entered at the time of initial implant, and it can be revised at any time.
6. Program the device to the **Device Off** mode to prepare it for the implant.

#### 4.1.5 How to open the sterile package

Open the sterile package containing the Micra AV transcatheter pacing system by following these instructions:

1. Open the end of the pouch that has the angle-shaped seal, the end where the device is located, and fold back the flaps.

**Figure 4.** Opening the pouch

---

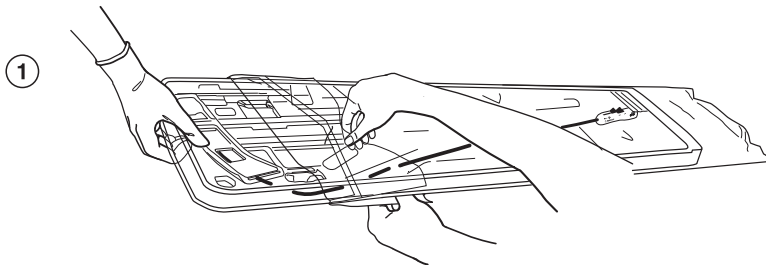

2. Remove the tray containing the transcatheter pacing system from the pouch and place the tray in the sterile field. Then, remove the tray cover.

**Figure 5.** Removing the tray and placing it in a sterile field

---

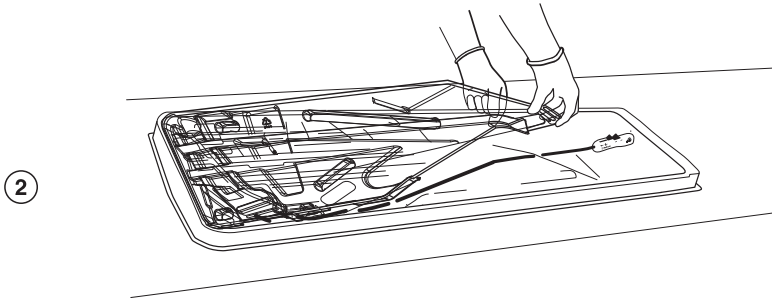

3. Hold the handle of the delivery catheter system with one hand and remove it from the tray, while holding the clamshell with the other hand.

**Figure 6.** Removing the delivery catheter system from the tray

---

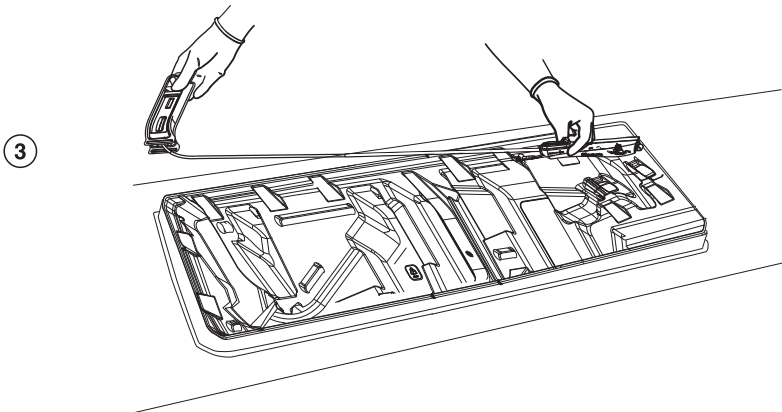

4. Open the clamshell and hold down the cover with one hand. With the other hand, hold the distal end of the delivery catheter system in mid position, as indicated by the arrows on the clamshell, and remove the system.

**Figure 7.** Removing the delivery catheter system from the clamshell

---

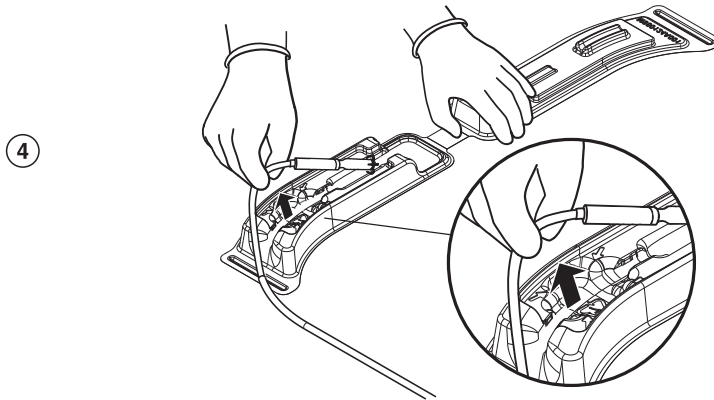

**Cautions:**

- After removing the delivery catheter system from the clamshell, check the system shaft for any damage or kinking. If there is any damage or kinking in the system shaft, do not use the transcatheter pacing system.
- Do not place the delivery catheter system back in the sterile tray after removing the system because doing so may expose the device to static buildup in the tray.

## 4.2 Implanting the device

The device implant consists of the following tasks:

- Performing the implant procedure
  - Preparing the delivery system and device for implant
  - Inserting a percutaneous introducer into the patient's femoral vein
  - Navigating the delivery system and deploying the device in the right ventricle
- Assessing the device fixation
  - Performing the pull and hold test
  - Taking the initial electrical measurements
  - Repositioning the device if necessary for proper fixation
- Completing the implant procedure
  - Completing the device programming
- Assessing the device performance

## 4.2.1 How to implant the device

**Warning:** The implant procedures in this section include the following potential hazards:

- Patient infection
- Acute tissue / vascular trauma
- Chronic trauma, including migration of product components
- Exposure to toxic materials
- Undesirable physiologic response

**Note:** Do not program the Rate Profile Optimization parameter to On before the implant procedure is completed.

This section describes how to prepare the delivery system and device for implant, insert the introducer into the patient's femoral vein, navigate the delivery system to the right ventricle, and deploy the device at the implant location.

**Figure 8.** Overview of the Micra AV transcatheter pacing system

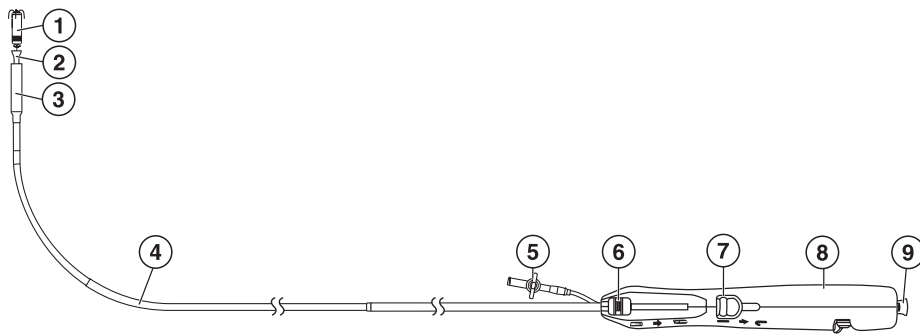

- 1 Micra AV device
- 2 Device recapture cone
- 3 Device cup
- 4 Delivery catheter
- 5 Flush port

- 6 Device deployment button
- 7 Catheter curve deflection button
- 8 Delivery system handle
- 9 Tether port



**Figure 9.** The Micra AV device

---



1 Micra AV device capsule  
2 Fixation tines

3 Pacing cathode  
4 Pacing anode

---

#### **4.2.1.1 How to prepare the Micra AV transcatheter pacing system for implant**

Observe the following warnings and instructions to prepare the delivery system and device for navigation through the femoral vein:

##### **Warnings:**

- The delivery system lumens contain air when the system is shipped. Use proper de-airing techniques before and during use to reduce the risk of air embolization.
  - Do not retract the device fixation tines all the way into the device cup until you are ready to insert the delivery catheter system into the introducer. Unlike the helix electrode of an active fixation lead, the device tines do not require pre-implant exercise. Excessively retracting the device tines into the device cup before implant could adversely affect their fixation performance.
1. Connect a syringe of saline to the flush port and flush the delivery system.
  2. Press down the deployment button on the delivery system handle to unlock the button. See Figure 10. Then slide the deployment button forward to retract the device into the device cup.
  3. While keeping the device retracted into the device cup, flush the delivery system again.

**Figure 10.** Micra AV delivery catheter system: deployment handle

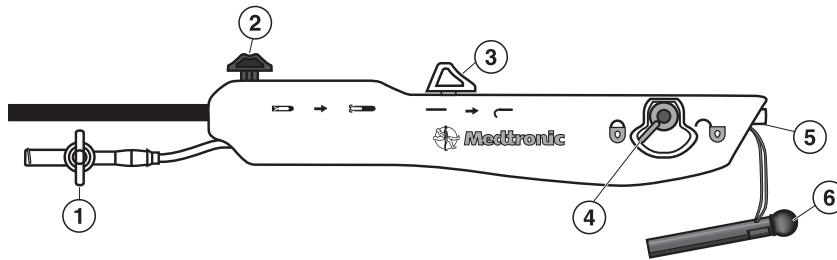

- |                                    |                       |
|------------------------------------|-----------------------|
| 1 Flush port                       | 4 Tether lock button  |
| 2 Device deployment button         | 5 Tether port         |
| 3 Catheter curve deflection button | 6 Tether retainer pin |

#### 4.2.1.2 How to insert a percutaneous introducer into the patient's femoral vein

**Note:** The procedure for inserting the Micra AV transcatheter pacing system into the femoral vein requires the use of a 7.8 mm (23 Fr) introducer sheath that is 56 cm (22 in) long or longer, such as the Medtronic Micra Introducer. For instructions on how to insert the percutaneous introducer, refer to its technical manual.

**Note:** Consider ultrasonic or echo-guided access to reduce risk of arterial puncture.

#### Warnings:

- To minimize the risk of air embolization, ensure proper de-airing of the introducer before inserting the delivery system into it.
- Before inserting the delivery system into the patient's femoral vein, aspirate and then flush the introducer through the introducer sideport. Use of a syringe that is 30 cm<sup>3</sup> or larger is recommended.

Before navigating the delivery system through the femoral vein, perform the following steps:

1. Advance the introducer with the dilator over the guidewire to the mid atrium.
2. Remove the dilator and guidewire.
3. Attach a continuous heparinized saline drip to the sideport on the introducer to prevent clot formation.

### 4.2.1.3 How to navigate the delivery system and deploy the device

#### Notes:

- While positioning and deploying the device, closely observe the fluoroscopic image for guidance.
- Avoid implant locations where the device can contact any existing devices or abandoned leads.
- Some patients may have unique anatomy that may make it more challenging to navigate to the target location; contrast injection may be useful to assist in visualizing anatomical details.

To navigate the delivery system and deploy the device at the implant location in the right ventricle, follow these instructions:

1. Continue to flush while you are inserting the delivery system into the introducer.

**Note:** Make sure that the tether lock button on the handle of the delivery system is in the lock position. See Figure 10.

**Note:** If you unlock the tether lock button prior to device deployment you increase the risk of premature device deployment.

**Caution:** To ensure that no damage is caused to the delivery system, hold the shaft of the system directly behind the device cup while inserting it into the introducer.

2. Advance the delivery system through the introducer into the right atrium.
3. Retract the introducer out of the atrium and down into the inferior vena cava (IVC).

**Note:** Make sure that the introducer is retracted far enough into the IVC so that you can deflect the curve of the delivery system.

4. Form a curve in the delivery system by sliding back the curve deflection button on the handle. See Figure 10.

**Warning:** When steering the delivery system, do not apply excessive pressure on the heart. Doing so may cause injury to the cardiac tissue or damage to the delivery system, or both problems. If you feel resistance, stop advancing the delivery system and use the fluoroscopic image to assess the tissue and the delivery system before proceeding.

5. Deflect the delivery system to cross the tricuspid valve. Release the deflection and navigate the delivery system to the implant location in the right ventricle.
6. Confirm the location of the delivery system from different fluoroscopic views (AP, LAO, and RAO).
7. Remove the tether retainer pin from the delivery system handle. See Figure 10.
8. Unlock the tether lock button.

**Warning:** If you do not unlock the tether lock button, the device may be dislodged when you attempt to retract the delivery system after deploying the device.

9. Applying adequate pressure at the tip of the delivery system, press down the deployment button on the handle. Then slide back the button half way. Release the tip pressure and continue to slide back the button all the way to deploy the device at the implant location.

**Warning:** Do not apply excessive pressure on the delivery system. Excessive pressure may cause damage to the device tines, damage to the delivery system, or cardiac perforation.

10. Retract the delivery system as far back as necessary to ensure that it has no interaction with the deployed device.

**Warning:** Before performing the pull and hold test to assess the adequacy of the device fixation, be sure to retract the delivery system far enough from the device to avoid an interaction with it. If any interaction with the device occurs during the pull and hold test, the test result may be incorrect.

For instructions on how to assess the device fixation, see Section 4.2.2.

## 4.2.2 How to assess the device fixation

After positioning the device in the right ventricle, it is important that you assess the adequacy of the device fixation in the patient's cardiac tissue. You can perform this assessment based on the pull and hold test result, the EGM waveform, and the initial electrical measurements.

### 4.2.2.1 How to perform the pull and hold test

The pull and hold test is designed to be an aid to determine whether the device is deployed properly and fixed adequately at the implant location.

**Note:** To help you assess the adequacy of the device fixation during the pull and hold test, magnify the fluoroscopic image of the device and record a cine loop of  $\geq 15$  FPS to view the device tines.

1. While gently putting tension on the tether of the delivery system, view the fluoroscopic image closely to examine the fixation of the device tines in the cardiac tissue. For an example of the tine fixation, see Figure 11.

If 2 or more of the 4 device tines are engaged firmly in the cardiac tissue, you can determine that the device fixation is adequate. If only one of the device tines, or none of them, is engaged, repositioning of the device is required. If 2 tines cannot be seen to be engaged, then another view, such as LAO, may be required to confirm. This action should be performed before repositioning the device. For instructions on how to reposition the device, see Section 4.2.2.3, "How to reposition the device during the implant procedure", page 55.

**Figure 11.** Assessment of the device tine fixation

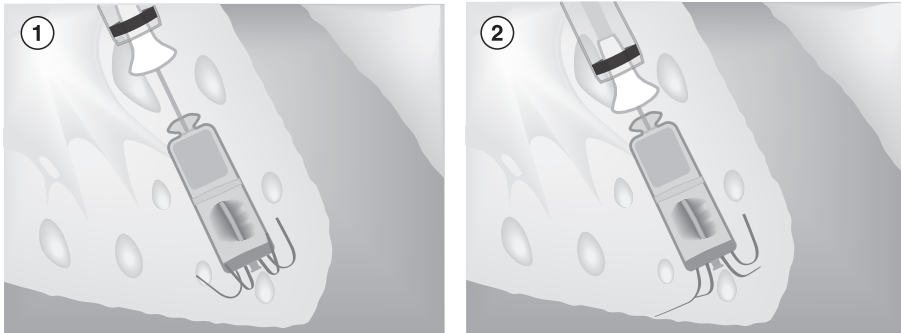

- 1 The device tines are curved toward the device when it is deployed at the implant location.
- 2 The device tines that are turned outward, as viewed on the fluoroscopic image while tension is applied to the device during the pull and hold test, indicate that they are engaged in the cardiac tissue. As shown in the illustration, the 3 tines that are in an outward position are engaged in the cardiac tissue, while the tine that remains curved toward the device is not engaged.

2. If the pull and hold test reveals that the device is fixed adequately, take the initial electrical measurements to check the sensing and pacing values. For information about how to take the initial electrical measurements from the programmer, see Section 4.2.2.2.

#### **4.2.2.2 How to take the initial electrical measurements**

The electrical measurement tests, performed after the pull and hold test, help you determine whether the sensing, electrode impedance, and pacing threshold values are acceptable for the device implant. To prepare for the electrical measurement tests, follow these instructions:

1. Place the programming head over the patient's heart to establish telemetry communication between the device and the programmer. To establish acceptable telemetry, it may be necessary to adjust the position of the programming head over the patient's heart. Position the programming head in such a way that 2 or more of the indicator lights for telemetry strength are illuminated, as required to ensure adequate telemetry strength when taking electrical measurements during the device implant.
2. Activate the implanted device by programming it from the **Device Off** mode to the **VVI** mode, the **VVIR** mode, or the **VOO** mode on the **Parameters** screen.

3. View the patient's EGM waveform displayed in the live rhythm monitor window to assess the stability of the heart rhythm.

**Caution:** Before taking the electrical measurements, be sure to pull back the delivery system from the device. If the delivery system is not pulled back far enough, the electrical measurements may be incorrect.

From the Tests - Device Measurements screen, you can perform the electrical measurement tests for sensing, electrode impedance, and pacing threshold in sequence. The test results shown on the Tests - Device Measurements screen provide a basis to assess the device fixation, in addition to the pull and hold test result and EGM waveform.

The Tests - Device Measurements screen also allows you to perform selected electrical measurement tests.

**Note:** To see a full description of the device measurements tests, consult the Micra AV SW044 Programming Guide.

Follow this procedure to take the initial electrical measurements of the implanted Micra AV device:

1. Establish telemetry with the device.
2. Tap **Tests > Device Measurements** to open the **Tests - Device Measurements** screen.  
Note that Sensing Test, Impedance Test, and Threshold Test are all selected to run in sequence. Uncheck any test that you do not wish to run at this time.
3. If you are running the Sensing Test and you want to change the values for Mode and Lower Rate, tap the corresponding **Test Value** field and select the new value.

**Warning:** Before you start the sensing test, select a temporary pacing rate that is likely to allow intrinsic sensed events and may be well tolerated by the patient. If the patient shows poor tolerance to the selected pacing rate when the test is in progress, tap **STOP**. To complete this test, the device must detect 2 consecutive ventricular sensed events with an interval of at least 500 ms (a heart rate of 120 bpm or slower) between them. If such an interval is not identified after 10 s, the device stops the test. If a pacing rate suitable to the patient is not available to select, consider omitting the Sensing Test from the device measurement tests.

4. Select the type of **Threshold Test** that you wish to run:
  - Select **Capture Management** to perform the automatic test.
  - Select **Amplitude - Auto Decrement** to perform the manual test.

**Note:** If you select **Amplitude – Auto Decrement**, a 2-test or 3-test sequence will suspend at the Threshold Test and you will be given an opportunity to select the test values in the **Tests - Pacing Threshold** window.

5. Tap **START Tests**. The programmer executes your selected test or tests. When each test starts, the programmer displays a message to indicate which test is progress. Wait for the programmer to complete each test.  
If you are running the manual Threshold Test, press **TEST Press and Hold** in the **Tests - Pacing Threshold** window until you lose capture.

6. Assess whether the test values shown on the screen for R-wave (Sensing Test), Impedance (Impedance Test), and Threshold (Threshold Test) are acceptable. If a test value is within the recommended range, a check mark appears next to this value. If a test value is not within the recommended range, a warning symbol appears next to this value. Consider repeating the related test or tests under adjusted parameters, if applicable. The recommended values are:
  - R-Wave:  $\geq 5$  mV
  - Impedance: 400 – 1500  $\Omega$
  - Threshold:  $\leq 1.00$  V
7. Tap **Save** to save the test values to the device memory. Tap **Patient > Implant...** to confirm the stored test values.
8. Tap **Print...** to print the test values.

**Notes:**

- If the electrical measurements are not acceptable, prepare the device for repositioning it in the right ventricle. See instructions in Section 4.2.2.3, “How to reposition the device during the implant procedure”, page 55, and repeat the pull and hold test and electrical measurement tests to assess the device fixation.
- If the electrical measurements continue to be unacceptable, this may indicate that blood clots are on the device electrodes.
  1. Remove the device from the patient’s body and flush the delivery catheter system and the device with heparinized saline to ensure that there are no blood clots on the device electrodes.
  2. Repeat the procedures in Section 4.2.1.3, “How to navigate the delivery system and deploy the device”, page 51, Section 4.2.2.1, “How to perform the pull and hold test”, page 52, and Section 4.2.2.2, “How to take the initial electrical measurements”, page 53.
- The tether can compromise the atrial mechanical sensing signal. Therefore, assessing AV synchrony during the implant procedure is not recommended.

### **4.2.2.3 How to reposition the device during the implant procedure**

If repositioning the device is required to achieve adequate fixation or acceptable electrical measurements, or both outcomes, it is necessary to deploy the device to a different location in the right ventricle and assess the adequacy of the device fixation at the new location.

1. Program the device to the **Device Off** mode.
2. Extend the recapture cone completely out of the device cup. Apply tension to the tether while advancing the delivery system back to the device until the recapture cone is in contact with the device.
3. View the fluoroscopic image from 2 views, such as LAO and RAO, to make sure that the recapture cone and device are aligned axially, as shown in Figure 12.

**Figure 12.** Retracting the device into the device cup

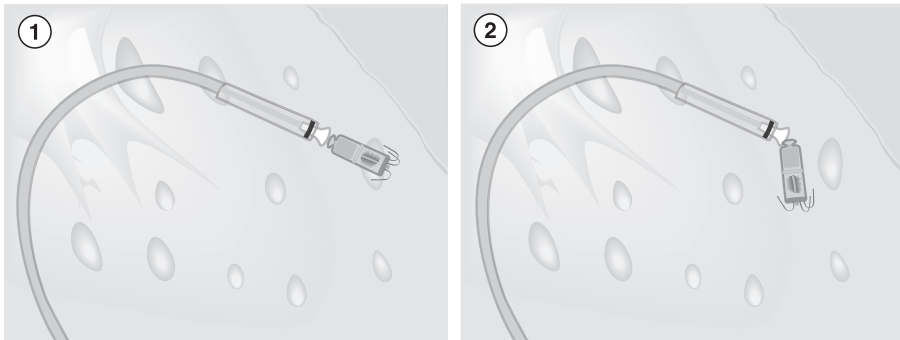

- 1 Correct alignment of the recapture cone with the device
- 2 Incorrect alignment of the recapture cone with device

4. Lock the tether lock button.
5. Retract the device into the device cup by pressing down the deployment button and then sliding the button forward. To make sure that the device is retracted completely, view the fluoroscopic image and verify that the device tines are fully inside the device cup.

If you recaptured the device into the device cup successfully, proceed to Step 6.

**Warning:** If you feel any resistance when advancing or retracting the deployment button, stop sliding this button. Cardiac tissue may be caught between the device cup and the device, or the device cup and the device may not be aligned axially. To avoid damage to the cardiac tissue or the device cup, or both, while attempting to recapture the device, follow these instructions:

- a. Unlock the tether lock button and release the device from the recapture cone.
- b. Flush the delivery system.
- c. Apply tension on the tether and attempt to advance the delivery system back to the device from a different angle than in the initial attempt.
- d. View the fluoroscopic image from 2 views, such as LAO and RAO, to make sure that the recapture cone and the device are aligned axially and that there is no gap between them. If a gap exists, pull harder on the tether while bringing the recapture cone toward the device.
- e. Attempt to recapture the device into the device cup while maintaining tension on the tether and gently sliding the deployment button forward.
- f. If you are unable to recapture the device, position the delivery system as close to the device as possible.
- g. Lock the tether lock button and pull the delivery system and device out of the cardiac tissue.
- h. If a gap exists between the device and the recapture cone, as viewed on the fluoroscopic image, unlock the tether lock button and retract the device by pulling on the tether.



- i. Lock the tether lock button and retract the device into the device cup by sliding the deployment button forward.
  - j. Proceed to Step 6.
6. Advance the delivery system to the new implant location.
  7. Unlock the tether lock button.
  8. Applying adequate pressure at the tip of the delivery system, press down the deployment button on the handle. Then slide the button back half way. Release the tip pressure and continue to slide the button back all the way to deploy the device at the implant location.

**Warning:** Do not apply excessive pressure on the delivery system. Excessive pressure may cause damage to the device tines, damage to the delivery system, or cardiac perforation.

9. Retract the delivery system as far back as necessary to ensure that the system has no interaction with the device.
10. Perform the pull and hold test to assess fixation of the device, as explained in Section 4.2.2.1, “How to perform the pull and hold test”, page 52.
11. Take electrical measurements for sensing, electrode impedance, and pacing threshold, and determine whether the test values are acceptable. For instructions, see Section 4.2.2.2, “How to take the initial electrical measurements”, page 53.

#### 4.2.2.4 Considerations for redeployment of the Micra AV device

If you have deployed the Micra AV device 3 to 5 times, consider the following:

- Ensure that there is adequate tip pressure.
- Consider a contrast injection to visualize the device cup against the endocardial wall.
- Remove the delivery system tool and check for clots.
- Consider an R-wave as low as 2 mV.
- Consider accepting a higher pacing threshold, depending on the pacing and longevity needs of the patient. (Consult the estimated longevity table.)

If you have deployed the Micra AV device 10 times or more, consider abandoning the system and reverting back to the traditional transvenous approach.

#### 4.2.3 How to complete the implant procedure

If you determine that the device fixation is adequate, based on the pull and hold test result, EGM waveform, and electrical measurements, complete the implant procedure and program the device parameters.

1. Before removing the tether, flush the lumens of the delivery system with heparinized saline.

**Warning:** If the delivery system lumens are not flushed with heparinized saline to remove any blood clots on the tether, the device may be dislodged when the tether is pulled out.

2. Make sure that the delivery system is positioned close to the device. Then cut one end of the tether and gently pull the tether out of the delivery system while viewing the fluoroscopic image to ensure that excessive force is not being applied to the implanted device.

**Caution:** Once the tether is cut, do not flush the delivery system until the tether has been fully removed. Flushing after cutting can cause the tether to tangle and can prolong the implant procedure.

**Caution:** If you feel resistance when pulling out the tether, advance the recapture cone closer to the device to avoid dislodgment of the device.

3. Remove the delivery system from the introducer.
4. Remove the introducer from the femoral vein.
5. Apply adequate pressure at the venous access site to obtain hemostasis.
6. Program the sensing and pacing parameters as appropriate for the patient.

**Warning:** Device dislodgment after the implant is possible due to interaction with other therapeutic devices or instruments. For warnings, precautions, and guidance for medical procedures on cardiac device patients, see Section 2.6, “Warnings, precautions, and guidance for clinicians performing medical procedures on cardiac device patients”, page 21.

#### 4.2.3.1 How to complete the device programming

**Note:** If the previously implanted Micra device has not been inactivated, program this device to the Device Off mode before completing the parameter programming for the new device.

To program parameter values for the new Micra AV, follow these instructions:

1. Verify that the pacing parameters are programmed to values that are appropriate for the patient.

**Notes:**

- Make sure that the programmed values for pulse width and amplitude parameters provide an adequate safety margin above the pacing threshold for the patient.
  - If you set the Sensitivity parameter to its most sensitive value, the device is more susceptible to electromagnetic interference (EMI) and oversensing. Oversensing may result in the inhibition of ventricular pacing.
2. Enter the patient’s information on the **Patient Information** screen.
  3. Program the **Data Collection Setup...** parameters.

#### 4.2.4 How to assess the device performance

Before the patient is discharged from the hospital, follow these steps to assess the performance of the implanted device:

1. Monitor the patient's electrocardiogram until the patient is discharged. If the device is dislodged, it usually occurs during the immediate postoperative period.
2. Check the pacing and sensing values, and adjust the programmed values if necessary.
3. Interrogate the device and print a Final Report to document the postoperative status of the programmed device.

#### 4.2.5 How to assess AV synchrony

The parameters that sense atrial mechanical activity to promote AV synchrony are set up by the atrial sensing setup process. This process is automated. It takes place following implant. It measures the A3 and A4 mechanical signals and sets the atrial sensing parameters according to these measurements.

To confirm AV synchrony following the atrial sensing setup process, connect a surface ECG between the patient and the programmer to review cardiac activity. If the ECG does not show good AV synchrony, perform the manual atrial mechanical test and adjust parameter values. See the Micra AV SW044 programming guide for details on the atrial sensing setup process and the manual atrial mechanical test procedure.

**Note:** The tether can compromise the atrial mechanical sensing signal.

### 4.3 Implanting a new Micra AV device in a patient with an existing Micra device

When the existing Micra device implanted in a patient has reached the Recommended Replacement Time (RRT) condition, the patient may require the implant of a new Micra AV device. The new Micra AV device should be implanted at a different location in the right ventricle. Avoid locations where the new device can contact any existing devices or abandoned leads. The existing device must be inactivated before completing the implant procedure for the new device.

For more information, see Section 4.3.4, "How to select the new Micra device in a patient with an existing Micra device", page 62.

**Caution:** A new Micra AV device or another device appropriate for the patient condition must be implanted before the existing device reaches End Of Service (EOS) condition. When an EOS condition is reached, a device permanently deactivates its pacing operation.

For instructions about how to prepare for the implant of the Micra AV device, see Section 4.1, "Preparing for an implant", page 43.

The major tasks required for the implant of the new Micra AV device are the same as those performed for the implant of the previous Micra device. However, the new device implant requires some additional steps in the implant procedures covered in the following sections:

- Navigating the delivery catheter system and deploying the device. See Section 4.3.2, “How to navigate the delivery catheter system and deploy the new Micra AV device”, page 61
- Assessing the device fixation. See Section 4.3.3, “How to assess the device fixation”, page 62
- Select the new device on the programmer. See Section 4.3.4, “How to select the new Micra device in a patient with an existing Micra device”, page 62.
- Completing the implant procedure. See Section 4.3.5, “How to complete the implant procedure”, page 63

For instructions about implant procedures that are the same as those performed when the previous Micra device was implanted, see the following sections:

- Preparing the delivery catheter system and device for implant. See Section 4.2.1, “How to implant the device”, page 48.
- Inserting a percutaneous introducer into the patient’s femoral vein. See Section 4.2.1.2, “How to insert a percutaneous introducer into the patient’s femoral vein”, page 50.
- Repositioning the device to achieve adequate device fixation or electrical measurements. See Section 4.2.2.3, “How to reposition the device during the implant procedure”, page 55.
- Assessing the device performance. See Section 4.2.4, “How to assess the device performance”, page 59.

### **4.3.1 Considerations for implanting the new Micra AV device**

Since the existing Micra device continues to provide pacing until it reaches the EOS condition, it is necessary to avoid the possibility of competitive pacing with the newly implanted Micra AV device. Before starting the procedure for the new device implant, take one of the following actions:

- If the patient needs pacing support during the implant of the new Micra AV device, consider programming the existing device to a pacing rate that is low enough to sense the patient’s intrinsic R-wave.
- If the patient is pacemaker-dependent, consider using a temporary pacemaker to provide pacing support during the implant of the new device.
- If the patient is not pacemaker-dependent, consider programming the existing device to the Device Off mode.

**Note:** Do not program the Rate Profile Optimization parameter to On before the implant procedure is completed.

### 4.3.2 How to navigate the delivery catheter system and deploy the new Micra AV device

#### Notes:

- While positioning and deploying the device, closely observe the fluoroscopic image for guidance.
- Some patients may have unique anatomy that may make it more challenging to navigate to the target location; contrast injection may be useful to assist in visualizing anatomical details.

To navigate the delivery system and deploy the new Micra AV device at the implant location in the right ventricle, follow the instructions in this section.

1. Insert the delivery system into the introducer.

**Note:** Make sure that the tether lock button on the handle of the delivery system is in the lock position. See Figure 10, page 50.

**Caution:** To ensure that no damage is caused to the delivery system, hold the shaft of the system directly behind the device cup while inserting it into the introducer.

2. Advance the delivery system through the introducer into the right atrium.
3. Retract the introducer out of the atrium and down into the inferior vena cava (IVC).

**Note:** Make sure that the introducer is retracted far enough into the IVC so that you can deflect the curve of the delivery system.

4. Form a curve in the delivery system by sliding back the curve deflection button on the handle. See Figure 10, page 50.

**Warning:** When steering the delivery system, do not apply excessive pressure on the heart. Doing so may cause injury to the cardiac tissue or damage to the delivery system, or both problems. If you feel resistance, stop advancing the delivery system and use the fluoroscopic image to assess the tissue and the delivery system before proceeding.

5. Deflect the delivery system to cross the tricuspid valve. Release the deflection and navigate the delivery system to the new implant location in the right ventricle.
6. Confirm the location of the delivery system from different fluoroscopic views (AP, LAO, and RAO).

**Note:** When positioning the new Micra AV device, avoid implant locations where the new device and its tines could contact the existing device or any abandoned leads. Mechanical interaction can result in oversensing.

7. Remove the tether retainer pin from the delivery system handle. See Figure 10, page 50.
8. Unlock the tether lock button.

**Warning:** If you do not unlock the tether lock button, the device may be dislodged when you attempt to retract the delivery system after deploying the device.

9. Applying adequate pressure at the tip of the delivery system, press down the deployment button on the handle. Then, slide back the button half way. Release the tip pressure and continue to slide back the button all the way to deploy the device at the implant location.

**Warning:** Do not apply excessive pressure on the delivery system. Excessive pressure may cause damage to the device tines, damage to the delivery system, or cardiac perforation.

10. Retract the delivery system as far back as necessary to ensure that it has no interaction with the deployed device.

**Warning:** Before performing the pull and hold test to assess the adequacy of the device fixation, be sure to retract the delivery system far enough from the device to avoid any interaction with it. If any interaction with the device occurs during the pull and hold test, the test result may be incorrect.

### 4.3.3 How to assess the device fixation

After deploying the new Micra AV device at the implant location, assess the device fixation by performing the pull and hold test. Following the pull and hold test, establish telemetry with the new device. After you establish telemetry with the new device, perform the initial electrical measurement tests for sensing, electrode impedance, and pacing threshold.

- To perform the pull and hold test, see Section 4.2.2.1, “How to perform the pull and hold test”, page 52.
- To select the new device in a patient with an existing device, see Section 4.3.4.
- To perform the initial electrical measurement tests, see Section 4.2.2.2, “How to take the initial electrical measurements”, page 53. For instructions about how to select the new Micra AV device for the initial electrical measurement tests, see Section 4.3.4.

In addition to these tests, assess the EGM waveform on the programmer screen to determine the adequacy of the device fixation. If it is necessary to reposition the device to achieve adequate fixation or obtain acceptable electrical measurements, follow the instructions in Section 4.2.2.3, “How to reposition the device during the implant procedure”, page 55.

### 4.3.4 How to select the new Micra device in a patient with an existing Micra device

If the patient is implanted with a new Micra device before a chronic Micra device reaches its EOS phase, you must select the new device to establish telemetry with the programmer. On the **Find Patient** screen, each implanted Micra device is identified by its model name, implant year, and the serial number specific to it. This information is available for the new device when it is programmed to **On**.

**Note:** The implant year of the new Micra device is appended to its model name on the **Find Patient** screen when the device is first programmed from the **Device Off** mode to an operating mode.

To select the new Micra device on the **Find Patient** screen, follow these instructions:

1. Tap the serial number of the new Micra device.
2. Tap **Interrogate...** from the command bar. You may also interrogate the device by pressing the I button on the programming head.
3. Tap **Start**.

### 4.3.5 How to complete the implant procedure

If you determine that the device fixation is adequate based on the pull and hold test result, EGM waveform, and electrical measurements, complete the implant procedure according to the instructions in this section.

#### 4.3.5.1 How to complete the device programming

**Note:** If the chronic Micra device has not been inactivated, select it in the **Find Patient** screen and program it to the Device Off mode before completing the parameter programming for the new device.

To program parameter values for the new Micra AV device, follow these instructions:

1. Verify that the pacing parameters are programmed to values that are appropriate for the patient.

**Notes:**

- Make sure that the programmed values for pulse width and amplitude parameters provide an adequate safety margin above the pacing threshold for the patient.
  - If you set the Sensitivity parameter to its most sensitive value, the device is more susceptible to electromagnetic interference (EMI) and oversensing. Oversensing may result in the inhibition of ventricular pacing.
2. Enter the patient's information on the Patient Information screen.
  3. Program the Data Collection Setup... parameters.

## 4.4 Retrieving and repositioning the device after the tether removal

The Micra AV device is designed to provide options at EOS or for situations where the physician determines that Micra AV therapy is no longer required. As there is currently no imaging modality that allows for determining level of encapsulation, the Micra AV device can be programmed to Device Off mode, permanently disabling therapy, and remain in the body. However, the Micra AV design allows for retrieval of the device with commercially available, off-the-shelf tools.

This section provides instructions on how to retrieve and reposition the implanted Micra AV device after removing the tether on the delivery system.

## Warnings:

- Retrieval of the device after it is fully encapsulated may result in injury to the patient's cardiac tissue. If device retrieval is required after it is encapsulated, refer the patient to a medical center that has expertise in the removal of implanted leads or call a Medtronic representative for more information.  
For related information, see Section 2.2, "Explant and disposal under care", page 17
- Keep external pacing equipment nearby for immediate use. The patient does not receive pacing therapy from the implanted device when it is being retrieved and repositioned.

### 4.4.1 Instruments, components, and accessories required for device retrieval

Make sure that you have all the instruments, system components, and sterile accessories required to perform the procedures for device retrieval and repositioning.

The following non-implanted instruments and equipment are required to retrieve and reposition the implanted device:

- Medtronic programmer with a Medtronic programming head
- Model SW044 software application
- External defibrillator

The following sterile system components and accessories are required to retrieve and reposition the implanted device:

- Micra Introducer
- Micra AV Model MC1AVR1 transcatheter pacing system

**Note:** If you need to reposition the device after removing the tether during the initial implant procedure, you can use the original introducer and delivery system. To reposition the device at a later date, a new introducer and new Micra AV Model MC1AVR1 system are required.

- Device retrieval snare that is 175 cm long or longer with a 3 Fr or smaller outer diameter

**Note:** For information about how to use the Micra Introducer and retrieval snare, refer to the technical manuals provided with these products.

### 4.4.2 How to retrieve the device after the tether removal

This section provides instructions on how to retrieve the implanted device, using a retrieval snare:

1. Program the device to the Device Off or the OVO mode to prepare it for retrieval.
2. Insert the introducer into the patient's femoral vein. For instructions on how to insert the introducer, see Section 4.2, "Implanting the device", page 47. Also, refer to the technical manual provided with the introducer.



3. Obtain the Micra AV system. If you are using a new Micra AV system, remove the device from the delivery system by cutting the tether and pulling the device out of the distal end of system.
4. Insert the proximal (non-looped) end of the snare wire into the distal end of the delivery system until this wire exits from the handle of the delivery system.
5. Front load the snare sheath over the snare wire through the lumen of the delivery system.
6. Insert the delivery system containing the snare into the introducer.

**Caution:** Do not lock the tether lock button on the delivery system. Locking the tether may cause damage to the snare.

**Figure 13.** Device retrieval snare inserted into the delivery system

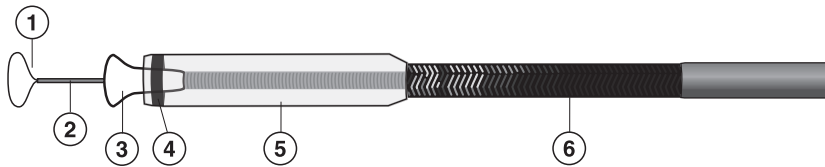

- |                  |                               |
|------------------|-------------------------------|
| 1 Snare loop     | 4 Marker for device retrieval |
| 2 Tether         | 5 Device cup                  |
| 3 Recapture cone | 6 Delivery catheter           |

7. Advance the delivery system through the introducer to the right atrium.
8. Retract the introducer out of the right atrium down to the IVC.
9. Steer the delivery system and snare loop close to the implanted device.
10. Under fluoroscopic guidance, advance the snare loop and place it around the proximal end of the device.

**Figure 14.** Using the snare to retrieve the device

---

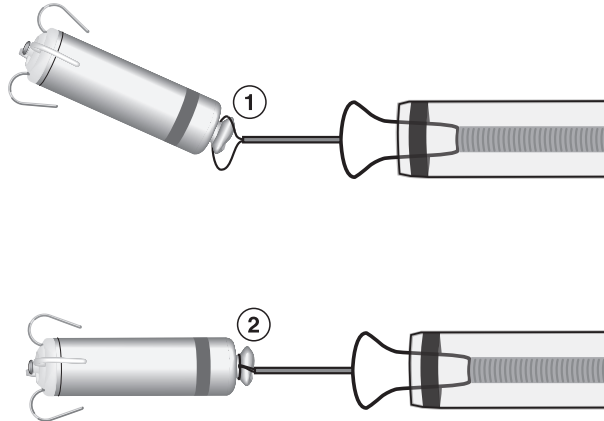

- 1 The snare loop is placed around the device.
  - 2 The snare loop is tightened to hold the device firmly.
- 

11. Tighten the snare loop around the device and maintain tension on it to ensure that it is holding the device firmly.
12. Retract the device into the delivery system by pushing down the deployment button and then sliding it up.

**Caution:** Do not lock the tether lock button on the delivery system. Locking the tether may cause damage to the snare.

#### 4.4.3 How to reposition the device after retrieval

After retrieving the implanted device into the delivery system, deploy it at a different implant location in the right ventricle and assess the adequacy of the device fixation at this location.

**Note:** The procedure for repositioning the device after retrieval is similar to repositioning the device during the initial implant procedure. However, use of the retrieval snare, instead of the tether, is required when performing the pull and hold test to assess the device fixation.

1. Advance the delivery system to the new implant location in the right ventricle.
2. Applying adequate pressure at the tip of the delivery system, push down the deployment button on the handle. Then, slide back the button to deploy the device at the implant location.
3. Retract the delivery system as far back as necessary to ensure that it has no interaction with the device.
4. Perform the pull and hold test by gently pulling on the snare, while viewing the fluoroscopic image closely to examine the fixation of the device tines. For further instructions on how to perform the pull and hold test, see Section 4.2.2.1, “How to perform the pull and hold test”, page 52.

5. Perform the programmer tests to take the initial electrical measurements. For instructions on how to take the electrical measurements, see Section 4.2.2.2, “How to take the initial electrical measurements”, page 53.  
**Note:** If the electrical measurements are not acceptable, retrieve the device into the delivery system and reposition it according to instructions in this section. Repeat all the tests required to assess the device fixation.
6. If the results of the pull and hold test and electrical measurements are acceptable, release the snare from the device. For instructions on how to release the snare, see the technical manual provided for this product.
7. Retract the delivery system and snare out of the introducer.
8. Remove the introducer from the femoral vein.
9. Obtain hemostasis at the venous access site.
10. Program the sensing and pacing parameters as appropriate for the patient.
11. Assess the device performance after repositioning it. For instructions on how to assess the device performance, see Section 4.2.2.2, “How to take the initial electrical measurements”, page 53.

# 5 Product specifications

## 5.1 Physical characteristics

**Table 15.** Physical characteristics of the device

---

Maximum volume	1 cm <sup>3</sup>
Length	25.9 mm
Outer diameter	6.7 mm (20.1 Fr)
Mass	1.75 g
Materials in chronic contact with human tissue <sup>a</sup>	Titanium, titanium nitride, parylene C, primer for parylene C, PEEK, siloxane, nitinol, platinum, iridium, liquid silicone rubber, and silicone medical adhesive
Steroid	Dexamethasone acetate, <1.0 mg, MCRD release mechanism
Fixation mechanism	Nitinol tines
Battery	Lithium-hybrid CFx silver vanadium oxide
Nominal pacing cathode	2.5 mm <sup>2</sup> , Pt sintered, TiN coated
Minimum pacing anode	22 mm <sup>2</sup> , TiN coated
Cathode to anode spacing	18 mm

---

<sup>a</sup> These materials have been successfully tested for the ability to avoid biological incompatibility. The device does not produce an injurious temperature in the surrounding tissue during normal operation.

**Figure 15.** Radiopaque ID as viewed on the fluoroscopic image

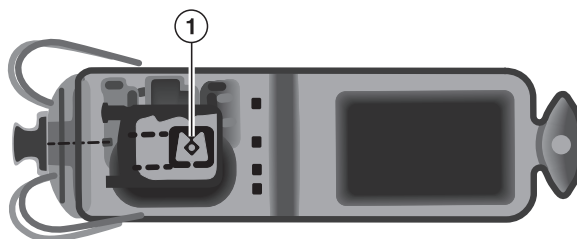

1 Radiopaque ID

---

**Table 16.** Physical characteristics of the delivery catheter<sup>a</sup>

---

Outer diameter	7.8 mm (23 Fr)
Effective length	105 cm (41.3 in)

---

<sup>a</sup> The delivery catheter contains no anti-thrombotic or antimicrobial additives or coatings.

## 5.2 Electrical specifications

**Table 17.** Battery characteristics

---

Manufacturer	Medtronic Energy and Component Center
Chemistry	Lithium-hybrid CFx silver vanadium oxide
Initial voltage	3.2 V
Mean usable capacity	120 mAh
Estimated time from RRT to EOS	6 months (180 days)

---

**Table 18.** Estimated current consumption

---

Current consumption (at 100% pacing) <sup>a</sup>	1.6 $\mu$ A
Current consumption (at 100% inhibition) <sup>b</sup>	0.9 $\mu$ A

---

<sup>a</sup> Current consumption when pacing into  $500 \Omega \pm 1\%$  loads at the Beginning of Service in VDD mode at 70 bpm, 1.5 V, and 0.24 ms.

<sup>b</sup> Current consumption when at the Beginning of Service in VDD mode at 70 bpm, 1.5 V, and 0.24 ms.

### 5.2.1 Output waveforms

**Figure 16.** Output waveform at nominal conditions (resistive load:  $500 \Omega$ )

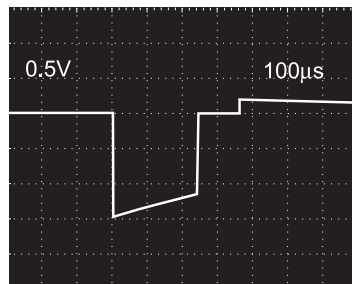

## 5.2.2 Variation with temperature

When the device temperature is within the 17 to 45°C (63 to 113°F) range, variations from the measured values obtained at the Beginning of Service (BOS) and at 37°C apply to the pacing rates, pacing intervals, sensing intervals, pulse width, pulse amplitude, and Sensitivity (sensing threshold) listed in Table 19.

**Table 19.** Variation with temperature between 17 and 45°C (63 and 113°F)

Parameter	Tolerance value
<ul style="list-style-type: none"> <li>• Lower Rate</li> <li>• Upper Sensor Rate</li> <li>• Pulse Width</li> <li>• Refractory</li> <li>• Blank Post VP</li> <li>• Blank Post VS</li> <li>• Rate Hysteresis</li> </ul>	±2%
Pulse amplitude	±0.13 V (±50 mV for amplitude values 0.13 V and 0.25 V)
Sensitivity (sensing threshold)	±15%

## 5.3 Replacement indicators

The battery voltage and messages about replacement status appear on the programmer display and on printed reports. The Recommended Replacement Time (RRT), Elective Replacement Indicator (ERI), and the End of Service (EOS) conditions are listed in Table 20.

**Table 20.** Replacement indicators

Recommended Replacement Time (RRT)	6 months (180 days) before EOS
Elective Replacement Indicator (ERI)	3 months (90 days) after RRT
End of Service (EOS)	3 months (90 days) after ERI or ≤2.5 V on 3 consecutive daily automatic measurements, whichever occurs first

**RRT date** – The programmer displays the date when the battery reached RRT on the Quick Look II and Battery and Device Measurements screens.

**RRT operation** – When the device reaches RRT, it continues to operate with its programmed parameters. During RRT operation, the following alert is issued when the device is interrogated: Replace device immediately.

**ERI operation** – When the battery voltage reaches the ERI condition, the device sets the pacing mode to VVI and the Lower Rate to 65 bpm. The device also sets Rate Hysteresis to Off. The RV Amplitude and RV Pulse Width parameter values remain as programmed. If the device is programmed to a non-pacing mode when it reaches ERI, it does not change the pacing mode or the lower rate.

**Note:** After ERI, all pacing parameters can be programmed, including mode and rate. Reprogramming the pacing parameters may reduce the duration of the ERI to EOS period.

**EOS condition** – When the battery voltage reaches the EOS condition, the device switches to the Device Off mode. The device permanently deactivates the pacing operation. The programmer indicates that the device is at EOS.

**Prolonged Service Period** – The Prolonged Service Period (PSP) is the time between the RRT and EOS indicators. The PSP is defined as 6 months (180 days), assuming the following conditions: 100% VDD pacing at 60 bpm, 1.5 V pacing amplitude; 0.24 ms pulse width; and 600 Ω pacing load. The EOS may be indicated before the end of 6 months if the device exceeds these conditions.

## 5.4 Projected service life

The projected service life in years for the device is shown in the following tables. The service life of the device is affected by the programmed settings for certain features, such as Rate Response.

Projected service life and estimates are based on accelerated battery discharge data and device modeling, as specified. Do not interpret these values as precise numbers.

**Note:** The longevity projections are based on typical shelf storage time. A maximum shelf life of 18 months will reduce usable capacity by 7.6 mAh, or 5.8%.

**Table 21.** Projected service life: VDD pacing

VDD pac- ing %	Ampli- tude	Pacing rate	Impe- dance	Longevity in years	
				Pulse width 0.24 ms	Pulse width 0.4 ms
0%	1.5 V	60 bpm	500 Ω	15.1	15.1
5%	1.0 V	60 bpm	500 Ω	14.8	14.7
	1.5 V	60 bpm	500 Ω	14.6	14.4
	2.0 V	60 bpm	500 Ω	14.3	14.0
50%	1.0 V	60 bpm	500 Ω	11.9	11.2
	1.5 V	60 bpm	500 Ω	10.8	9.7
	2.0 V	60 bpm	500 Ω	9.5	8.1
100%	1.0 V	60 bpm	500 Ω	10.2	9.2
	1.5 V	60 bpm	500 Ω	8.6	7.3
	2.0 V	60 bpm	500 Ω	6.9	5.4
	2.5 V	60 bpm	500 Ω	5.8	4.3
100%	1.5 V	60 bpm	400 Ω	8.1	6.7
	1.5 V	60 bpm	600 Ω	9.0	7.7

**Table 21.** Projected service life: VDD pacing (continued)

VDD pac- ing %	Ampli- tude	Pacing rate	Impe- dance	Longevity in years	
				Pulse width 0.24 ms	Pulse width 0.4 ms
100%	1.5 V	70 bpm	500 Ω	8.0	6.7
	1.5 V	100 bpm	500 Ω	6.8	5.5
100%	2.5 V	60 bpm	600 Ω	6.3	4.8
	3.5 V	60 bpm	500 Ω	3.7	2.5
	5.0 V	60 bpm	500 Ω	2.0	1.4

**Table 22.** Projected service life: VVIR pacing

VVIR pac- ing %	Ampli- tude	Pacing rate	Impe- dance	Longevity in years	
				Pulse width 0.24 ms	Pulse width 0.4 ms
0%	1.5 V	60 bpm	500 Ω	15.1	15.1
5%	1.0 V	60 bpm	500 Ω	15.0	14.9
	1.5 V	60 bpm	500 Ω	14.8	14.6
	2.0 V	60 bpm	500 Ω	14.5	14.2
50%	1.0 V	60 bpm	500 Ω	13.6	12.7
	1.5 V	60 bpm	500 Ω	12.2	10.9
	2.0 V	60 bpm	500 Ω	10.6	8.9
100%	1.0 V	60 bpm	500 Ω	12.1	10.8
	1.5 V	60 bpm	500 Ω	10.0	8.3
	2.0 V	60 bpm	500 Ω	7.8	6.0
	2.5 V	60 bpm	500 Ω	6.4	4.7
100%	1.5 V	60 bpm	400 Ω	9.3	7.6
	1.5 V	60 bpm	600 Ω	10.5	8.9
100%	1.5 V	70 bpm	500 Ω	9.4	7.7
	1.5 V	100 bpm	500 Ω	8.1	6.4
100%	2.5 V	60 bpm	600 Ω	7.0	5.2
	3.5 V	60 bpm	500 Ω	4.0	2.6
	5.0 V	60 bpm	500 Ω	2.1	1.4

**Table 23.** Projected service life: ISO 14708-2

Pacing mode	Pacing %	Ampli- tude	Pacing rate	Impe- dance	Pulse width	Longevity in years
VDD	100%	2.5 V	60 bpm	600 Ω	0.4 ms	4.7
VDD	100%	5.0 V	60 bpm	600 Ω	0.4 ms	1.6



**Table 24.** Projected service life: EN 45502-2-1

<b>Pacing mode</b>	<b>Pacing %</b>	<b>Amplitude</b>	<b>Pacing rate</b>	<b>Impedance</b>	<b>Pulse width</b>	<b>Longevity in years</b>
VDD	100%	2.5 V	70 bpm	500 $\Omega$	0.4 ms	3.9
VDD	100%	5.0 V	70 bpm	500 $\Omega$	0.4 ms	1.2

## 6 Device parameters

### 6.1 Emergency settings

**Table 25.** Emergency VVI settings

Parameter	Value
Mode	VVI
Lower Rate	70 bpm
Sensitivity	2.00 mV
Amplitude	5.00 V
Pulse Width	1.00 ms
Blank Post VP	240 ms
Blank Post VS	120 ms
Rate Hysteresis	Off

### 6.2 Pacing parameters

**Table 26.** Modes, rate, and intervals

Parameter	Programmable values	Shipped	Reset
Mode	VDD $\diamond$ ; VDI; VVIR; VVI; VOO; ODO; OVO; Device Off	Device Off	VVI
Lower Rate <sup>a,b,c</sup>	30; 35; 40 ... 50 $\diamond$ ; 55; 60; 70; 75; 80; 90 ... 170 bpm	50 bpm	65 bpm
Upper Tracking Rate	80; 90; 95; 100; 105 $\diamond$ ; 110; 115 bpm	105 bpm	105 bpm
Activity Mode Switch	On $\diamond$ ; Off	On	On
AV Conduction Mode Switch	On $\diamond$ ; Off	On	On

<sup>a</sup> The corresponding pulse interval can be calculated as follows: pulse interval (ms) = 60,000/Lower Rate.

<sup>b</sup> The escape interval is within -10/+25 ms of the programmed rate, measured in accordance with ISO 14708-2:2012 (Clause 6.1.5).

<sup>c</sup> Programmable values for Lower Rate do not include 65 bpm.

**Table 27.** Atrial parameters

Parameter	Programmable values	Shipped	Reset
A. Sensing Vector	1; 2; 3; 1+2 $\diamond$ ; 1+3; 2+3; 1+2+3	1+2	1+2
Live Waveform Display	Rectified $\diamond$ ; Vector 1 Source; Vector 2 Source; Vector 3 Source	Rectified	Rectified
A3 Threshold	1.0; 1.2; 1.4 ... 4.0 $\diamond$ ; 4.5; 5.0 ... 10.0; Max m/s <sup>2</sup>	4.0 m/s <sup>2</sup>	4.0 m/s <sup>2</sup>
Auto	On $\diamond$ ; Off	On	On
A3 Window End	600; 625 ... 775 $\diamond$ ... 1000 ms	775 ms	775 ms
Auto	On $\diamond$ ; Off	On	On
Min Auto A3 Window End	600; 625 ... 750 $\diamond$ ; 775; 800 ms	750 ms	750 ms
Max Auto A3 Window End	650; 675 ... 900 $\diamond$ ; 925 ... 1000 ms	900 ms	900 ms
A4 Threshold <sup>a</sup>	0.7; 0.8; 0.9; 1.0; 1.2 $\diamond$ ; 1.4 ... 3.0; 3.5; 4.0 ... 8.0 m/s <sup>2</sup>	1.2 m/s <sup>2</sup>	1.2 m/s <sup>2</sup>
Auto	On $\diamond$ ; Off	On	On
Min Auto A4 Threshold	0.7; 0.8 $\diamond$ ; 0.9; 1.0; 1.2; 1.4; 1.6 m/s <sup>2</sup>	0.8 m/s <sup>2</sup>	0.8 m/s <sup>2</sup>
Sensed AV (AM-VP)	20 $\diamond$ ; 30 ... 200 ms	20 ms	20 ms
PVAB	450; 500; 550 $\diamond$ ; 600 ms	550 ms	550 ms
PVARP	Auto $\diamond$ ; 500; 550 ... 750 ms	Auto	Auto
Max PVARP	500; 550; 600 $\diamond$ ... 750 ms	600 ms	600 ms
Rate Smoothing	On $\diamond$ ; Off	On	On
Smoothing Delta	50; 100 $\diamond$ ; 150; 200 ms	100 ms	100 ms
Tracking Check <sup>b</sup>	On $\diamond$ ; Off	On	On
Tracking Check Rate	90; 100 $\diamond$ ; 110 bpm	100 bpm	100 bpm
Atrial Sensing Setup <sup>c</sup>	On/Restart; Off/Complete $\diamond$	On/Restart	Off/Complete

<sup>a</sup> The range of values for this parameter can also be considered the atrial sensitivity range for the device.

<sup>b</sup> Tracking Check will extend PVARP and limit tracking when programmed to On.

<sup>c</sup> Check atrial sensing parameters after atrial sensing setup has completed.

**Table 28.** RV parameters

Parameter	Programmable values	Shipped	Reset
RV Amplitude	0.13; 0.25; 0.38; 0.50; 0.63; 0.75; 0.88; 1.00; 1.13; 1.25; 1.38; 1.50 $\diamond$ ; 1.63; 1.75; 1.88; 2.00; 2.13; 2.25; 2.38; 2.50; 2.63; 2.75; 2.88; 3.00; 3.13; 3.25; 3.38; 3.50; 3.63; 3.75; 3.88; 4.00; 4.13; 4.25; 4.38; 4.50; 4.63; 4.75; 4.88; 5.00 V	2.5 V	3.5 V
RV Pulse Width	0.09; 0.15; 0.24 $\diamond$ ; 0.40; 1.00 ms	0.24 ms	0.24 ms
RV Sensitivity	0.45; 0.60; 0.90; 1.50; 2.00 $\diamond$ ; 2.80; 4.00; 5.60; 8.00; 11.30 mV <sup>a,b</sup>	2.00 mV	2.00 mV
Acute Phase Remaining	Device Repositioned (112 days) $\diamond$ ; Off	Device Repositioned (112 days)	Device Repositioned (112 days)
RV Blanking			
Blank Post VP	150; 160 ... 240 $\diamond$ ... 450 ms	240 ms	240 ms
Blank Post VS	120 $\diamond$ ; 130 ... 350 ms	120 ms	120 ms

<sup>a</sup> Carefully evaluate the possibility of increased susceptibility to EMI and oversensing before changing the sensitivity threshold to its minimum (most sensitive) setting. When susceptibility to interference is tested under the conditions specified in ISO 14708-2 clause 27.4 and EN 45502-2-1 clause 27.5.1, the device may sense the interference if the sensitivity threshold is programmed to the minimum value. The device complies with the requirements of ISO 14708-2 clause 27.4 and EN 45502-2-1 clause 27.5.1 when the sensitivity threshold is programmed to 0.6 mV or higher.

<sup>b</sup> Patients who require the lowest sensitivity threshold (0.45 mV) should be under medical direction.

**Table 29.** RV Capture Management... parameters

Parameter	Programmable values	Shipped	Reset
RV Capture Management	Adaptive $\diamond$ ; Monitor; Off	Adaptive	Adaptive
RV Amplitude Safety Margin	0.25; 0.50 $\diamond$ ... 1.50 V	0.50 V	0.50 V

**Table 30.** Rate Response parameters

Parameter	Programmable values	Shipped	Reset
Rates			
ADL Rate	60; 65 ... 95 $\diamond$ ... 160 bpm	95 bpm	95 bpm
Upper Sensor Rate	80; 90 ... 120 $\diamond$ ... 170 bpm	120 bpm	120 bpm

**Table 30.** Rate Response parameters (continued)

Parameter	Programmable values	Shipped	Reset
Rate Profile Optimization	On $\diamond$ ; Off	On	On
Adjust Rate Response			
ADL Response	1; 2; 3 $\diamond$ ; 4; 5	3	3
Exertion Response	1; 2; 3 $\diamond$ ; 4; 5	3	3
Rate Response Additional Parameters <sup>a</sup>			
Activity Acceleration	15; 30 $\diamond$ ; 60 s	30 s	30 s
Activity Deceleration	Exercise $\diamond$ ; 2.5; 5; 10 min	Exercise	Exercise

<sup>a</sup> The following parameters and their programmed values are shown in the Rate Response Additional Parameters window, but they must be adjusted in the Tests - Exercise screen: Activity Vector, LR Setpoint, ADL Setpoint, UR Setpoint. Tap **Tests > Exercise** to access these parameters.

**Table 31.** MRI SureScan parameters

Parameter	Programmable values	Shipped	Reset
MRI SureScan	On; Off	Off	Off
MRI Pacing Mode	VOO; OVO	—	—
MRI Pacing Rate	60; 70; 75; 80; 90 ... 120 bpm	—	—

**Table 32.** Additional pacing features

Parameter	Programmable values	Shipped	Reset
Rate Hysteresis <sup>a</sup>	Off $\diamond$ ; 30; 40 ... 80 bpm	Off	Off

<sup>a</sup> The programmed value for Rate Hysteresis must be lower than the Lower Rate value unless Rate Hysteresis is programmed to Off.

## 6.3 Data collection setup parameters

**Table 33.** Data Collection Setup parameters

Parameter	Programmable values	Shipped	Reset
Device Date/Time <sup>a</sup>	(enter current date and time)	—	—
Holter Telemetry	Off $\diamond$ ; 0.5; 1; 2; 4; 8; 16; 24 hr	Off	Off

<sup>a</sup> The times and dates stored in data are determined by the Device Date/Time clock.

## 6.4 Test parameters

The following sections provide parameter names and values for tests provided with the Micra AV MC1AVR1 device.

### 6.4.1 Device measurement test parameters

**Table 34.** Device measurements tests

Parameter	Selectable values
<b>Sensing Test</b>	
Temp. Mode	VVI; OVO
Temp. Lower Rate	30; 35 ... 60; 70; 75; 80; 90 ... 170 bpm
<b>Threshold Test</b>	
	Capture Management Amplitude - Auto Decrement
<b>Tests - Pacing Threshold<sup>a</sup></b>	
Decrement after / Pulses per decrement	2; 3 ... 15 pulses
Temp. Mode <sup>b</sup>	VVI; VOO
Temp. Lower Rate	30; 35 ... 60; 70; 75; 80; 90 ... 170 bpm
Temp. RV Amplitude	0.13; 0.25; 0.38; 0.50; 0.63 ... 5.00 V
Temp. RV Pulse Width	0.09; 0.15; 0.24; 0.40; 1.00 ms
Temp. V. Pace Blanking	150; 160 ... 450 ms

<sup>a</sup> Parameters for selected Amplitude - Auto Decrement threshold test.

<sup>b</sup> The selectable test values for this parameter depend on the permanently programmed pacing mode.

### 6.4.2 Temporary test parameters

**Table 35.** Temporary test parameters

Parameter	Selectable values
Mode	VVI; VOO; OVO
Lower Rate	30; 35; 40 ... 60; 70; 75; 80; 90 ... 170 bpm
Amplitude	0.13; 0.25; 0.38; 0.50; 0.63 ... 5.00 V
Pulse Width	0.09; 0.15; 0.24; 0.40; 1.00 ms
Sensitivity	0.45; 0.60; 0.90; 1.50; 2.00; 2.80; 4.00; 5.60; 8.00; 11.30 mV

### 6.4.3 Manual atrial mechanical test parameters

**Table 36.** Manual Atrial Mechanical test parameters

Parameter	Selectable values
Temp. Mode	VDD; VDI; ODO
Temp. Lower Rate	30; 35; 40 ... 60; 70; 75; 80; 90 ... 170 bpm
Temp. A. Sensing Vector	1; 2; 3; 1+2; 1+3; 2+3; 1+2+3
Temp. A3 Threshold	1.0; 1.2; 1.4 ... 4.0; 4.5; 5.0 ... 10.0; Max m/s <sup>2</sup>
Temp. A3 Window End	600; 625; 650 ... 1000 ms
Temp. A4 Threshold	0.7; 0.8; 0.9; 1.0; 1.2; 1.4 ... 3.0; 3.5; 4.0 ... 8.0 m/s <sup>2</sup>

### 6.4.4 Exercise test parameters

**Table 37.** Exercise test parameters

Parameter	Programmable values	Shipped	Reset
Duration	5; 20 min	20 min	20 min
Activity Vector <sup>a</sup>	Vector 1; Vector 2; Vector 3	Vector 1	Vector 1
LR Setpoint <sup>a</sup>	0; 1; 2 ... 40; 42 ... 50	30	30
ADL Setpoint <sup>a</sup>	5; 6 ... 40; 42 ... 80; 85 ... 100	42	42
UR Setpoint <sup>a</sup>	15; 16 ... 40; 42 ... 80; 85 ... 200	60	60

<sup>a</sup> These are the rate response additional parameters; however, they can only be programmed from the Tests - Exercise screen. To see these parameters in the Rate Response Additional Parameters window, tap Params > Rate Response... > Additional Parameters....

## 6.5 Nonprogrammable parameters

**Table 38.** Nonprogrammable parameters

Parameter	Value
Pacing rate limit (runaway pacing rate protection)	195 bpm
Minimum input impedance	150 kΩ
Pacing output capacitance	2.2 μF

# 7 Packaging symbols and declaration of conformity









## 7.1 Declaration of compliance to standards

Medtronic declares that this product is in conformity with the essential requirements of EN ISO 14971:2012.

## 7.2 Explanation of symbols















The following table contains symbols that apply to the Micra AV Model MC1AVR1 device.

**Table 39.** Explanation of symbols on package labeling









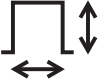

Symbol	Explanation
	MR Conditional. The SureScan pacing system is safe for use in the MRI environment when used according to the instructions in the Medtronic MRI Technical Manual.
	Medtronic SureScan symbol
	Adaptive
	Catheter
	Do not use if package is damaged
	Do not reuse
	Sterilized using ethylene oxide
	Product documentation
	Consult instructions for use



**Table 39.** Explanation of symbols on package labeling (continued)

Symbol	Explanation
	Date of manufacture
	Use by
	Reorder number
	Pace
	Sense
	Pacemaker (dual chamber, RA, RV)
	Transcatheter pacemaker
	Accelerometer
	Serial number
	Temperature limit
	Package contents
	Deployable tines
	Catheter delivered
	Transcatheter pacing system

**Table 39.** Explanation of symbols on package labeling (continued)

Symbol	Explanation
	Implantable device (coated)
	Amplitude/pulse width
	Outer diameter
	Sensitivity: RV
	Sensitivity: RA
	Sensed A-V interval
	PVARP
	Pacing polarity
	Upper tracking rate / lower rate
	Sensing polarity: RA, RV
	Steroid eluting DXAC
<b>VVIR</b>	VVIR pacing mode
<b>VDD</b>	VDD pacing mode
<b>Rx Only</b>	<b>Caution:</b> Federal law (USA) restricts this device to sale by or on the order of a physician



# Medtronic

**Medtronic, Inc.**

710 Medtronic Parkway  
Minneapolis, MN 55432  
USA  
[www.medtronic.com](http://www.medtronic.com)  
+1 763 514 4000

**Medtronic USA, Inc.**

Toll-free in the USA (24-hour technical consultation for  
physicians and medical professionals)  
Bradycardia: +1 800 505 4636  
Tachycardia: +1 800 723 4636

**Technical manuals**

[www.medtronic.com/manuals](http://www.medtronic.com/manuals)

© 2020 Medtronic  
M995148A001 B  
2020-01-22



\*M995148A001\*